

MAPEC

MOVING SOLUTIONS



materials

D

ACETAL RESIN

The acetal resin offers very good mechanical specifications, excellent wear resistance and a low coefficient of friction. Used in the manufacturing of plates for flat top chains, it is an economical alternative to our LFA material. FDA (Food and Drug Administration) approved for direct contact with food.

Working temperatures:

- 40° C / + 80° C (dry environment)
- 40° C / + 65° C (wet environment)

Colour: grey, white



SLX

EXTRA ADDITIVATED ACETAL RESIN

Internally lubricated polyacetal for high-speed applications. Recommended on application for PET containers and bottling lines. Increased wear resistance. FDA (Food and Drug Administration) approved for direct contact with food.

Working temperatures:

- 40° C / + 80° C (dry environment)
- 40° C / + 65° C (wet environment)

Colour: light grey



LFA / WAF / WLF

LOW FRICTION ACETAL RESIN

This material has a low coefficient of friction, high wear resistance and excellent resistance to chain tension. It is recommended for high load, high speed applications. FDA (Food and Drug Administration) approved for direct contact with food.

Working temperatures:

- 40° C / + 80° C (dry environment)
- 40° C / + 65° C (wet environment)

LFA colours: light brown, blue
WAF/WLF colour: white



AK

HIGH WEAR RESISTANT ACETAL RESIN

Very special material with aramid fibers and low friction coefficient recommended on dry applications for glass container, PET container and bottling lines.

Working temperatures:

- 40° C / + 80° C (dry environment)
- 40° C / + 65° C (wet environment)

Colour: dark grey, yellow



SP

SUPER PERFORMANCE ACETAL RESIN

The super performance resin has a lower coefficient of friction than LFA material. Plate wear and pitch elongation are reduced; it is suitable for high speed applications and reduced lubrication. FDA (Food and Drug Administration) approved for direct contact with food.

Working temperatures:

- 40° C / + 80° C (dry environment)
- 40° C / + 65° C (wet environment)

Colour: dark grey



MDA

ACETAL RESIN WITH A LOW COEFFICIENT OF FRICTION DETECTABLE BY A METAL DETECTOR

Acetal resin detectable by a metal detector or to X-ray machine. Material for use in production and packaging in the food industry. The blue color is optimal for facilitating optical detection by an operator or a camera. It has the same mechanical characteristics as LFA material while also protecting against the build-up of electrostatic charges. FDA (Food and Drug Administration) approved for direct contact with food.⁽¹⁾

Working temperature:

- 40° C / + 80° C (dry environment)
- 40° C / + 65° C (wet environment)

Colour: blue



WRX

WEAR RESISTANT POLYAMIDE COMPOSITE

It is especially wear resistant in abrasive environment and it is suitable for conveying glass containers, mechanical components, sand, etc.

Working temperatures:

- 20° C / + 120° C
(dry environment)

Colour: black



AS

ANTISTATIC ACETAL RESIN

This material offers great protection against static electrical charges. It is ideal for explosive atmosphere and where an electrostatic force may cause product instability.

Working temperatures:

- 40° C / + 80° C
(dry environment)
- 40° C / + 65° C
(wet environment)

Colour: black



PPB

CHEMICAL RESISTANT REINFORCED POLYPROPYLENE

This improved polypropylene has acid and corrosion resistance characteristics; it is specially recommended when a chain is exposed to chemical agents.

Working temperatures:

+ 5° C / + 105° C
(dry environment)
+ 5° C / + 105° C
(wet environment)

PPB chains dimensions are larger than those indicated in the drawing. To know dimensions refer to our Technical Department.

Colour: white

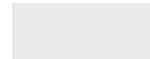

PBT

EXTRA PERFORMANCE POLYESTER RESIN (Available upon request)

It has a very low coefficient of friction and offers an excellent wear resistance. Plate wear and pitch elongation are reduced. It is specially developed for high speed and dry running applications.

Working temperatures:

- 40° C / + 125° C
(dry environment)
- 40° C / + 60° C
(wet environment)

Colour:
green, white, black

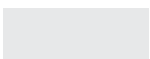

HT

GLASS REINFORCED POLYESTER RESIN (Available upon request)

Material with an extremely high resistance to the heat and wear. FDA (Food and Drug Administration) approved for direct contact with food.⁽¹⁾

Working temperatures:

- 40° C / + 140° C
(dry environment)

Colour: black, white

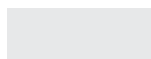

PINS D TYPE
Better seal on the hinge.

SYMBOLS



ZERO GAP
It improves the stability of the transported product.

⁽¹⁾ For chains supplied with pins in AISI 304/316 only

thermoplastic straight running chains

SINGLE HINGE - 820 SERIES

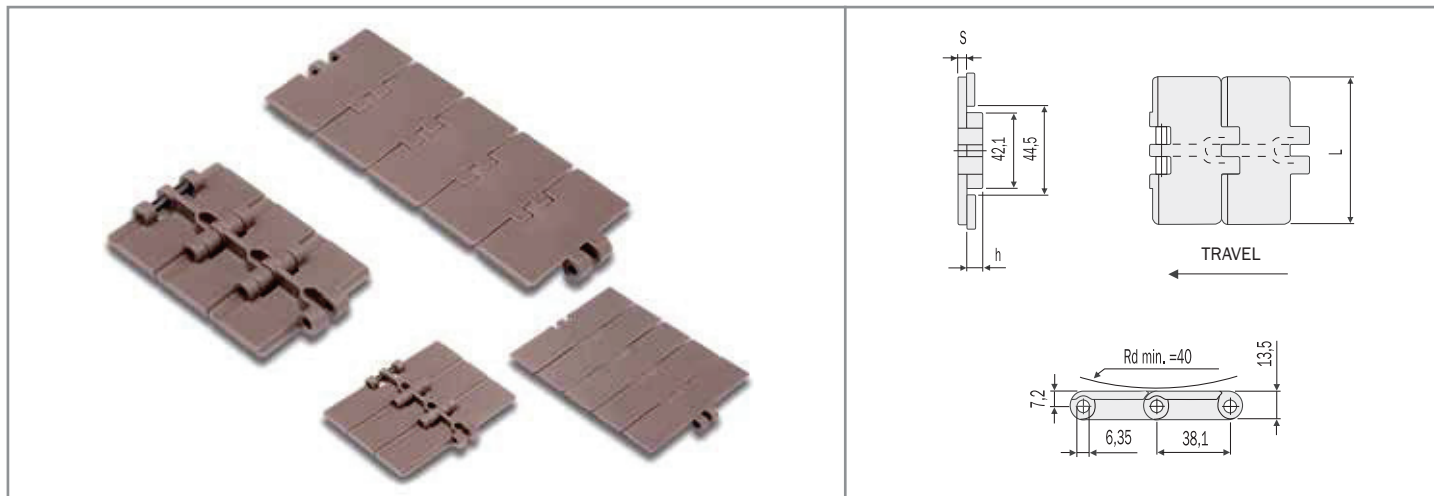

D 820 - ACETAL RESIN

- Plates in self-lubricating acetal resin, grey-coloured.
- Pins in special chrome-nickel stainless steel, work hardened for high resistance.



p.169
p.210



p.230
p.232

PRODUCT CODE	INTERNAL CODE	CHARACTERISTICS				
		Width L (mm)	Thickness S (mm)	Height h (mm)	Working Load Max N (21°C)	Weight kg/m
D 820 K250	6.00.020	63.5	4	9.5	1230	0.73
D 820 K325	6.00.040	82.5	4	9.5	1230	0.83
D 820 K343	6.00.043	87.0	4	9.5	1230	0.85
D 820 K350	6.00.060	88.9	4	9.5	1230	0.85
D 820 K400	6.00.070	101.6	4	9.5	1230	0.95
D 820 K450	6.00.080	114.3	4	9.5	1230	1.03
D 820 K600	6.00.100	152.4	4	9.5	1230	1.25
D 820 K750	6.00.110	190.5	4	9.5	1230	1.47

LFA 820 - LOW FRICTION ACETAL RESIN

- Plates in self-lubricating low friction acetal resin, light brown-coloured.
- Pins in special chrome-nickel stainless steel, work hardened for high resistance.



p.169
p.210



p.230
p.232

PRODUCT CODE	INTERNAL CODE	CHARACTERISTICS				
		Width L (mm)	Thickness S (mm)	Height h (mm)	Working Load Max N (21°C)	Weight kg/m
LFA 820 K250	6.10.020	63.5	4	9.5	1230	0.73
LFA 820 K325	6.10.040	82.5	4	9.5	1230	0.83
LFA 820 K330	6.10.042	83.8	4	9.5	1230	0.83
LFA 820 K343	6.10.043	87.0	4	9.5	1230	0.85
LFA 820 K350	6.10.060	88.9	4	9.5	1230	0.85
LFA 820 K400	6.10.070	101.6	4	9.5	1230	0.95
LFA 820 K450	6.10.080	114.3	4	9.5	1230	1.03
LFA 820 K500	6.10.090	127.0	4	9.5	1230	1.10
LFA 820 K600	6.10.100	152.4	4	9.5	1230	1.25
LFA 820 K750	6.10.110	190.5	4	9.5	1230	1.47

- Standard shipping lengths = 80 pitches = 10 feet = 3,048 metres.
- The above-mentioned chains can also be produced in acetal resin, white-coloured. (FOR D820)
- These chains can be supplied either with pins in austenitic stainless steel, work hardened, highly wear resistant, or with pins in thermoplastic resin.

SP 820 - SUPER PERFORMANCE ACETAL RESIN

- Plates in self-lubricating very low friction acetal resin, dark grey-coloured.
- Pins in special chrome-nickel stainless steel, work hardened for high resistance.

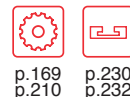

PRODUCT CODE	INTERNAL CODE	CHARACTERISTICS				
		Width L (mm)	Thickness S (mm)	Height h (mm)	Working Load Max N (21°C)	Weight kg/m
SP 820 K325	6.20.040	82.5	4	9.5	1230	0.83
SP 820 K330	6.20.042	83.8	4	9.5	1230	0.83
SP 820 K343	6.20.043	87.0	4	9.5	1230	0.85
SP 820 K350	6.20.060	88.9	4	9.5	1230	0.87
SP 820 K400	6.20.070	101.6	4	9.5	1230	0.95
SP 820 K450	6.20.080	114.3	4	9.5	1230	1.03
SP 820 K600	6.20.100	152.4	4	9.5	1230	1.25
SP 820 K750	6.20.110	190.5	4	9.5	1230	1.47

- Standard shipping lengths = 80 pitches = 10 feet = 3,048 metres.
- These chains can be supplied either with pins in austenitic stainless steel, work hardened, highly wear resistant, or with pins in thermoplastic resin.

AK 820 - HIGH WEAR RESISTANT ACETAL RESIN

- Plates in a very special acetal resin with aramidic fibers, dark grey-coloured.
- Pins in special chrome-nickel stainless steel, work hardened for high resistance.

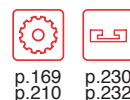

PRODUCT CODE	INTERNAL CODE	CHARACTERISTICS				
		Width L (mm)	Thickness S (mm)	Height h (mm)	Working Load Max N (21°C)	Weight kg/m
AK 820 K325	6.80.040	82.5	4	9.5	1230	0.83
AK 820 K330	6.80.042	83.8	4	9.5	1230	0.83
AK 820 K343	6.80.043	87.0	4	9.5	1230	0.85
AK 820 K350	6.80.060	88.9	4	9.5	1230	0.87
AK 820 K400	6.80.070	101.6	4	9.5	1230	0.95
AK 820 K450	6.80.080	114.3	4	9.5	1230	1.03
AK 820 K600	6.80.100	152.4	4	9.5	1230	1.25
AK 820 K750	6.80.110	190.5	4	9.5	1230	1.47

- Standard shipping lengths = 80 pitches = 10 feet = 3,048 metres.
- The above-mentioned chains can also be produced in special acetal resin, with aramidic fibers yellow-coloured.
- These chains can be supplied either with pins in austenitic stainless steel, work hardened, highly wear resistant, or with pins in thermoplastic resin.

WRX 820 - WEAR RESISTANT POLYAMIDE COMPOSITE

- Plates in thermoplastic wear resistant polyamide composite, black-coloured.
- Pins in special chrome-nickel stainless steel, work hardened for high resistance.

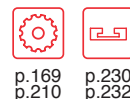

PRODUCT CODE	INTERNAL CODE	CHARACTERISTICS				
		Width L (mm)	Thickness S (mm)	Height h (mm)	Working Load Max N (21°C)	Weight kg/m
WRX 820 K325	6.50.040	82.5	4	9.5	1230	0.83
WRX 820 K343	6.50.043	87.0	4	9.5	1230	0.85
WRX 820 K350	6.50.060	88.9	4	9.5	1230	0.87
WRX 820 K400	6.50.070	101.6	4	9.5	1230	0.95
WRX 820 K450	6.50.080	114.3	4	9.5	1230	1.03

- Standard shipping lengths = 80 pitches = 10 feet = 3,048 metres.
- These chains can be supplied either with pins in austenitic stainless steel, work hardened, highly wear resistant.

AS 820 - ANTISTATIC ACETAL RESIN

- Plates in antistatic conductive acetal resin, black-coloured.
- Pins in special chrome-nickel stainless steel, work hardened for high resistance.



p.169
p.210



p.230
p.232

PRODUCT CODE	INTERNAL CODE	CHARACTERISTICS				
		Width L (mm)	Thickness S (mm)	Height h (mm)	Working Load Max N (21°C)	Weight kg/m
AS 820 K325	6.30.040	82.5	4	9.5	1230	0.83
AS 820 K350	6.30.060	88.9	4	9.5	1230	0.87
AS 820 K400	6.30.070	101.6	4	9.5	1230	0.95
AS 820 K450	6.30.080	114.3	4	9.5	1230	1.03
AS 820 K600	6.30.100	152.4	4	9.5	1230	1.25
AS 820 K750	6.30.110	190.5	4	9.5	1230	1.47

- Standard shipping lengths = 80 pitches = 10 feet = 3,048 metres.
- These chains can be supplied either with pins in austenitic stainless steel, work hardened, highly wear resistant, or with pins in thermoplastic resin.

PPB 820 - CHEMICAL RESISTANT REINFORCED POLYPROPYLENE

- Plates in chemical resistant reinforced polypropylene, white-coloured.
- Pins in chrome-nickel austenitic stainless steel (18% Chrome – 8% Nickel), work hardened for high resistance.



p.169
p.210



p.230
p.232

PRODUCT CODE	INTERNAL CODE	CHARACTERISTICS				
		Width L (mm)	Thickness S (mm)	Height h (mm)	Working Load Max N (21°C)	Weight kg/m
PPB 820 K325	6.40.040	82.5	4	9.5	1000	0.70
PPB 820 K350	6.40.060	88.9	4	9.5	1000	0.74
PPB 820 K400	6.40.070	101.6	4	9.5	1000	0.82
PPB 820 K450	6.40.080	114.3	4	9.5	1000	0.90
PPB 820 K600	6.40.100	152.4	4	9.5	1000	1.05
PPB 820 K750	6.40.110	190.5	4	9.5	1000	1.20

- Standard shipping lengths = 80 pitches = 10 feet = 3,048 metres.
- These chains can be supplied either with pins in austenitic stainless steel, 316 series, work hardened, highly wear resistant, or with pins in reinforced polypropylene.
- PPB chains dimensions are larger than those indicated in the drawing. To know dimensions refer to our Technical Department.

PBT 820 - EXTRA PERFORMANCE POLYESTER RESIN

- Plates in low friction polyester resin, green-coloured.
- Pins in special chrome-nickel stainless steel, work hardened for high resistance.



p.169
p.210



p.230
p.232

PRODUCT CODE	INTERNAL CODE	CHARACTERISTICS				
		Width L (mm)	Thickness S (mm)	Height h (mm)	Working Load Max N (21°C)	Weight kg/m
PBT 820 K325	6.70.040	82.5	4	9.5	1230	0.83
PBT 820 K350	6.70.060	88.9	4	9.5	1230	0.85
PBT 820 K400	6.70.070	101.6	4	9.5	1230	0.95
PBT 820 K450	6.70.080	114.3	4	9.5	1230	1.03
PBT 820 K600	6.70.100	152.4	4	9.5	1230	1.25
PBT 820 K750	6.70.110	190.5	4	9.5	1230	1.47

- Standard shipping lengths = 80 pitches = 10 feet = 3,048 metres.
- The above-mentioned chains can also be produced in extra performance polyester resin, white-coloured.
- These chains can be supplied either with pins in austenitic stainless steel, work hardened, highly wear resistant, or with pins in thermoplastic resin.

thermoplastic straight running chains

SINGLE HINGE - 831 SERIES - REINFORCED TOP PLATE

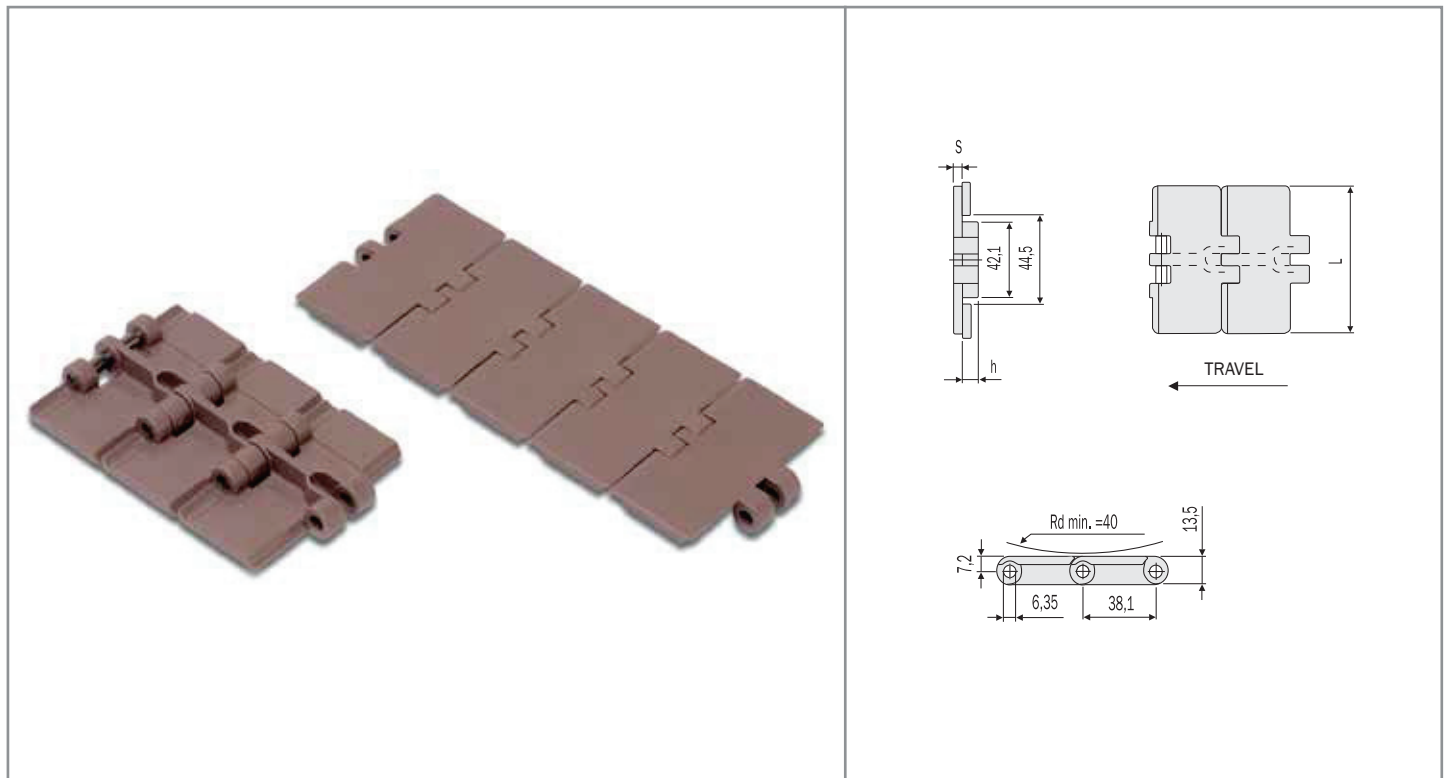

LFA 831 - LOW FRICTION ACETAL RESIN

- Plates in self-lubricating low friction acetal resin, light brown-coloured. **Top plate thickness 4,8mm.**
- Pins in special chrome-nickel stainless steel, work hardened for high resistance.

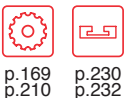

PRODUCT CODE	INTERNAL CODE	CHARACTERISTICS				
		Width L (mm)	Thickness S (mm)	Height h (mm)	Working Load Max N (21°C)	Weight kg/m
LFA 831 K325	6.11.040	82.5	4,8	8.7	1230	1.00
LFA 831 K330	6.11.042	83.8	4,8	8.7	1230	1.02
LFA 831 K400	6.11.070	101.6	4,8	8.7	1230	1.15
LFA 831 K450	6.11.080	114.3	4,8	8.7	1230	1.24
LFA 831 K600	6.11.100	152.4	4,8	8.7	1230	1.51
LFA 831 K750	6.11.110	190.5	4,8	8.7	1230	1.76

- Standard shipping lengths = 80 pitches = 10 feet = 3,048 metres.
- These chains can be supplied either with pins in austenitic stainless steel, work hardened, highly wear resistant, or with pins in thermoplastic resin.

SP 831 - SUPER PERFORMANCE ACETAL RESIN

- Plates in self-lubricating very low friction acetal resin, dark grey-coloured.
- Pins in special chrome-nickel stainless steel, work hardened for high resistance.

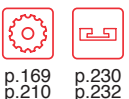

PRODUCT CODE	INTERNAL CODE	CHARACTERISTICS				
		Width L (mm)	Thickness S (mm)	Height h (mm)	Working Load Max N (21°C)	Weight kg/m
SP 831 K325	6.21.040	82.5	4,8	8.7	1230	1.00
SP 831 K330	6.21.042	83.8	4,8	8.7	1230	1.02
SP 831 K400	6.21.070	101.6	4,8	8.7	1230	1.15
SP 831 K450	6.21.080	114.3	4,8	8.7	1230	1.24
SP 831 K600	6.21.100	152.4	4,8	8.7	1230	1.51
SP 831 K750	6.21.110	190.5	4,8	8.7	1230	1.76

- Standard shipping lengths = 80 pitches = 10 feet = 3,048 metres.
- These chains can be supplied either with pins in austenitic stainless steel, work hardened, highly wear resistant, or with pins in thermoplastic resin.

thermoplastic straight running chains

SINGLE REINFORCED HINGE - 828 SERIES - HIGH LOAD CAPACITY

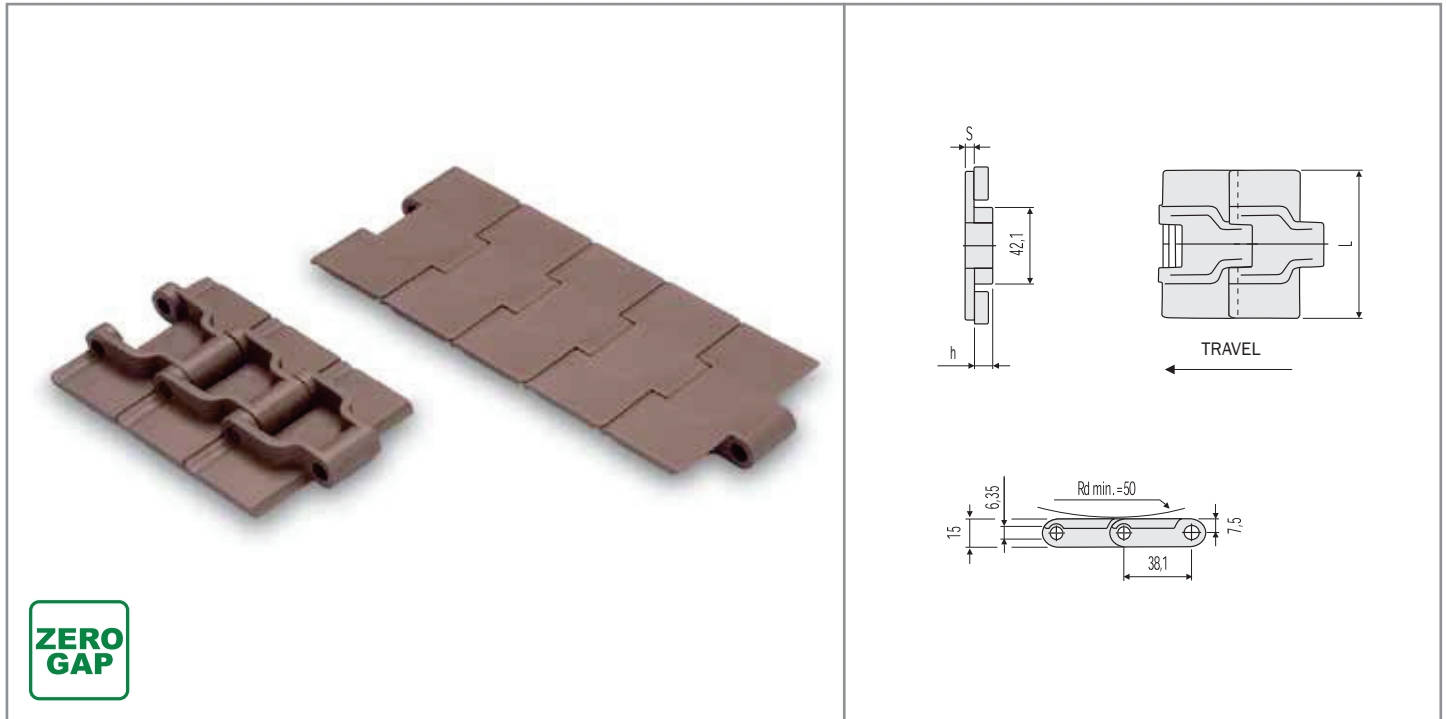

LFA 828 - LOW FRICTION ACETAL RESIN

- Plates in self-lubricating low friction acetal resin, light brown-coloured.
- Pins in special chrome-nickel stainless steel, work hardened for high resistance.



p.182
p.211



p.230
p.232

PRODUCT CODE	INTERNAL CODE	CHARACTERISTICS				
		Width L (mm)	Thickness S (mm)	Height h (mm)	Working Load Max N (21°C)	Weight kg/m
LFA 828 K325	6.18.240	82.5	4	11	2100	1.05
LFA 828 K330	6.18.242	83.8	4	11	2100	1.08

SP 828 - SUPER PERFORMANCE ACETAL RESIN

- Plates in self-lubricating very low friction acetal resin, dark grey-coloured.
- Pins in special chrome-nickel stainless steel, work hardened for high resistance.



p.182
p.211



p.230
p.232

PRODUCT CODE	INTERNAL CODE	CHARACTERISTICS				
		Width L (mm)	Thickness S (mm)	Height h (mm)	Working Load Max N (21°C)	Weight kg/m
SP 828 K325	6.28.240	82.5	4	11	2100	1.05
SP 828 K330	6.28.242	83.8	4	11	2100	1.08

AK 828 - HIGH WEAR RESISTANT ACETAL RESIN

- Plates in a very special acetal resin with aramid fibers, dark grey-coloured.
- Pins in special chrome-nickel stainless steel, work hardened for high resistance.



p.182
p.211



p.230
p.232

PRODUCT CODE	INTERNAL CODE	CHARACTERISTICS				
		Width L (mm)	Thickness S (mm)	Height h (mm)	Working Load Max N (21°C)	Weight kg/m
AK 828 K325	6.88.240	82.5	4	11	2100	1.05
AK 828 K330	6.88.242	83.8	4	11	2100	1.08

- Standard shipping lengths = 80 pitches = 10 feet = 3,048 metres.
- The above-mentioned chains can also be produced in special acetal resin, with aramid fibers yellow-coloured. (FOR AK 828)
- These chains can be supplied either with pins in austenitic stainless steel, work hardened, highly wear resistant, or with pins in thermoplastic resin.

thermoplastic straight running chains

SINGLE REINFORCED HINGE - 8257 SERIES

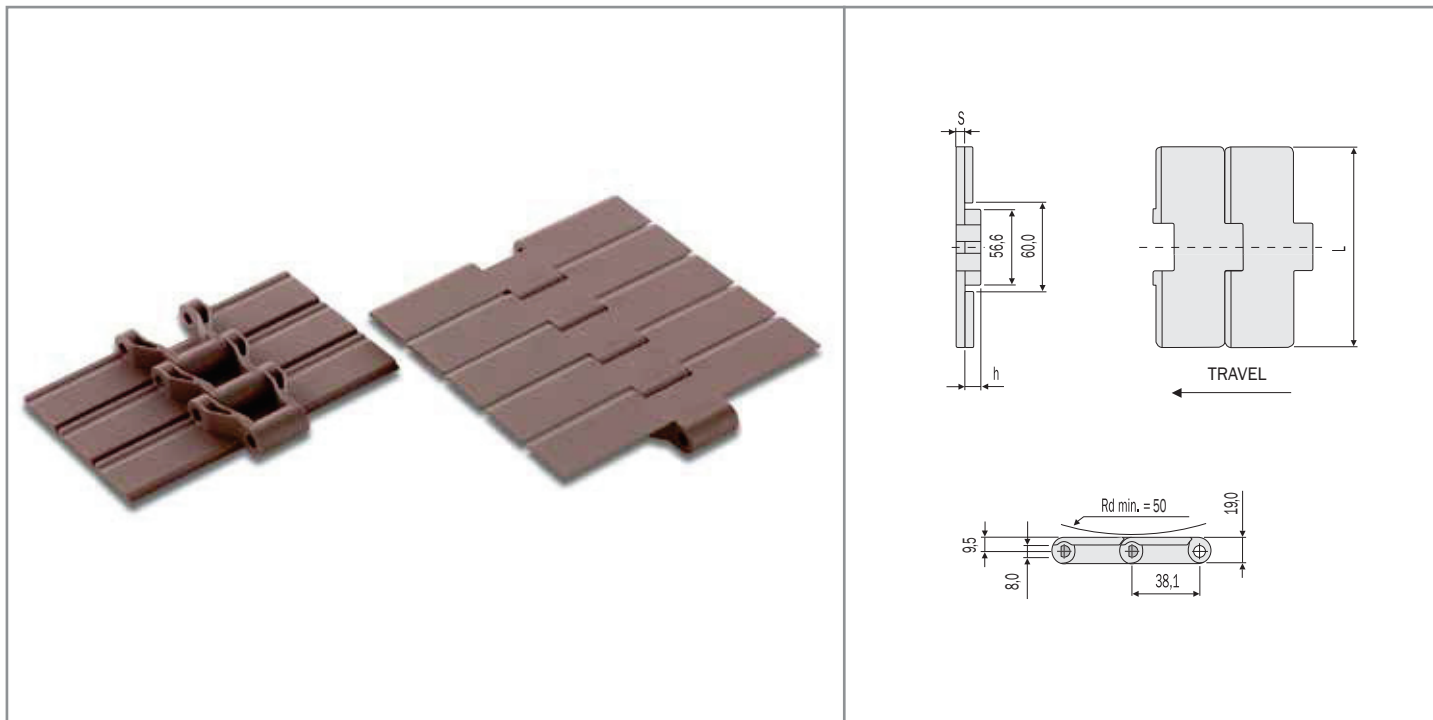

LFA 8257 - LOW FRICTION ACETAL RESIN

- Plates in self-lubricating low friction acetal resin, light brown-coloured.
- Pins in special stainless steel, 400 series, work hardened, magnetic, highly wear resistant.



p.188
p.212



p.230
p.232

PRODUCT CODE	INTERNAL CODE	CHARACTERISTICS				
		Width L (mm)	Thickness S (mm)	Height h (mm)	Working Load Max N (21°C)	Weight kg/m
LFA 8257 K750	6.10.175	190.5	4,8	14.2	3830	2.20
LFA 8257 K1000	6.10.185	254.0	4,8	14.2	3830	2.55
LFA 8257 K1200	6.10.195	304.8	4,8	14.2	3830	2.90

- Standard shipping lengths = 80 pitches = 10 feet = 3,048 metres.
- These chains can be supplied either with pins in austenitic stainless steel, work hardened, highly wear resistant, or with pins in thermoplastic resin.

SP 8257 - SUPER PERFORMANCE ACETAL RESIN

- Plates in self-lubricating very low friction acetal resin, dark grey coloured.
- Pins in special stainless steel, 400 series, work hardened, magnetic, highly wear resistant.



p.188
p.212



p.230
p.232

PRODUCT CODE	INTERNAL CODE	CHARACTERISTICS				
		Width L (mm)	Thickness S (mm)	Height h (mm)	Working Load Max N (21°C)	Weight kg/m
SP 8257 K750	6.20.175	190.5	4,8	14.2	3830	2.20
SP 8257 K1000	6.20.185	254.0	4,8	14.2	3830	2.55
SP 8257 K1200	6.20.195	304.8	4,8	14.2	3830	2.90

- Standard shipping lengths = 80 pitches = 10 feet = 3,048 metres.
- These chains can be supplied either with pins in austenitic stainless steel, work hardened, highly wear resistant, or with pins in thermoplastic resin.

thermoplastic straight running chains

DOUBLE HINGE - 821 SERIES

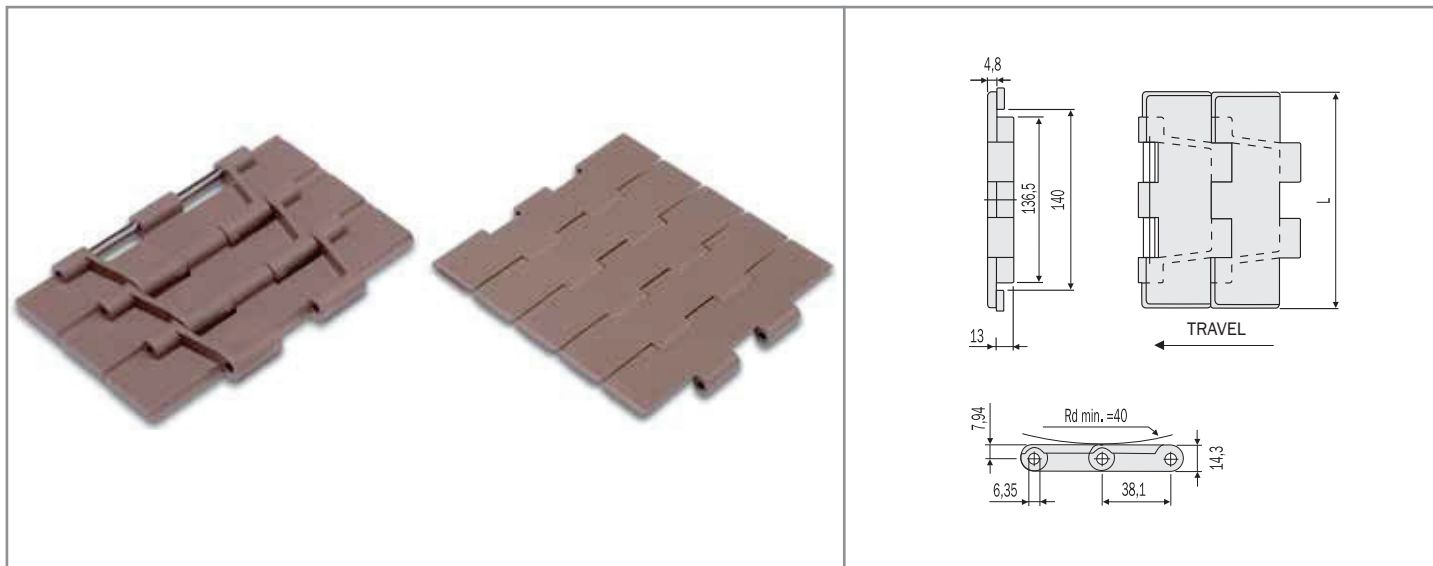

LFA 821 - LOW FRICTION ACETAL RESIN

- Plates in self-lubricating low friction acetal resin, light brown-coloured.
- Pins in special chrome-nickel stainless steel, work hardened for high resistance.



p.176
p.211



p.230
p.232

PRODUCT CODE	INTERNAL CODE	CHARACTERISTICS		
		Width L (mm)	Working Load Max N (21°C)	Weight kg/m
LFA 821 K750	6.14.110	190.5	2680	2.50
LFA 821 K1000	6.14.120	254.0	2680	2.95
LFA 821 K1200	6.14.130	304.8	2680	3.25

SP 821 - SUPER PERFORMANCE ACETAL RESIN

- Plates in self-lubricating very low friction acetal resin, dark grey-coloured.
- Pins in special chrome-nickel stainless steel, work hardened for high resistance.



p.176
p.211



p.230
p.232

PRODUCT CODE	INTERNAL CODE	CHARACTERISTICS		
		Width L (mm)	Working Load Max N (21°C)	Weight kg/m
SP 821 K750	6.24.110	190.5	2680	2.50
SP 821 K1000	6.24.120	254.0	2680	2.95
SP 821 K1200	6.24.130	304.8	2680	3.25

PPB 821 - CHEMICAL RESISTANT REINFORCED POLYPROPYLENE

- Plates in chemical resistant reinforced polypropylene, white-coloured.
- Pins in chrome-nickel austenitic stainless steel (18% Chrome - 8% Nickel), work hardened for high resistance.



p.176
p.211



p.230
p.232

PRODUCT CODE	INTERNAL CODE	CHARACTERISTICS		
		Width L (mm)	Working Load Max N (21°C)	Weight kg/m
PPB 821 K750	6.44.110	190.5	2680	2.50
PPB 821 K1000	6.44.120	254.0	2680	2.95
PPB 821 K1200	6.44.130	304.8	2680	3.25

- Standard shipping lengths = 80 pitches = 10 feet = 3,048 metres.
- These chains can be supplied with pins in austenitic stainless steel, work hardened, highly wear resistant. (FOR LFA 821 - SP 821)
- These chains can be supplied with pins in austenitic stainless steel, 316 series, work hardened, highly wear resistant. (FOR PPB 821)
- PPB chains dimensions are larger than those indicated in the drawing. To know dimensions refer to our Technical Department.

thermoplastic sideflexing chains

880 / 879 BEVEL SERIES

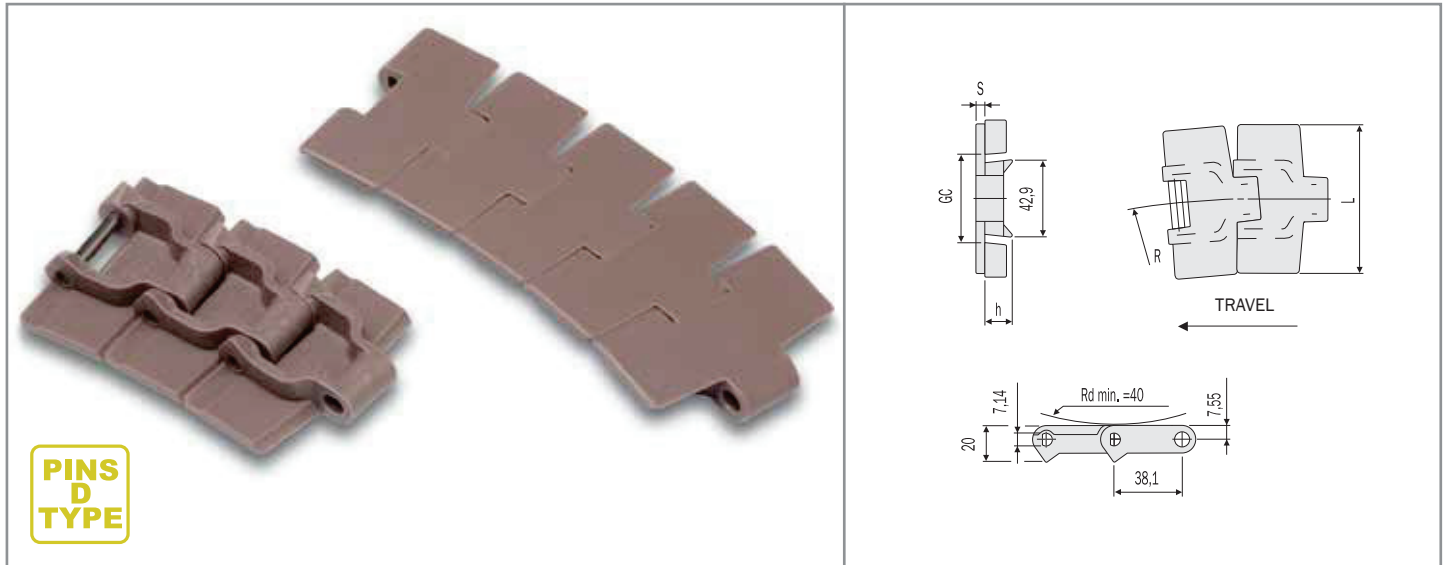

LFA 880 - LOW FRICTION ACETAL RESIN

- Plates in self-lubricating low friction acetal resin, light brown-coloured.
- Pins in special chrome-nickel stainless steel, work hardened for high resistance.



PRODUCT CODE	INTERNAL CODE	CHARACTERISTICS							
		L (mm)	S (mm)	h (mm)	R (mm)	GC st. (mm)	GC sid. (mm)	Work. Load Max N (21°C)	Weight kg/m
LFA 880 K325	6.12.040	82.5	4	16	400	44.5	41.4	2100	0.89
LFA 880 K330	6.12.044	83.8	4	16	400	44.5	41.4	2100	0.90
LFA 880 K350	6.12.060	88.9	4	16	400	44.5	41.4	2100	0.91
LFA 880 K450	6.12.080	114.3	4	16	400	44.5	41.4	2100	1.04
LFA 880 K750	6.12.110	190.5	4	16	400	44.5	41.4	2100	1.40

- Standard shipping lengths = 80 pitches = 10 feet = 3,048 metres.
- These chains can be supplied either with pins in austenitic stainless steel, work hardened, highly wear resistant or with pins in thermoplastic resin.

LFA 879 - LOW FRICTION ACETAL RESIN

TOP PLATE THICKNESS 4,8mm

- Plates in self-lubricating low friction acetal resin, light brown-coloured.
- Pins in special chrome-nickel stainless steel, work hardened for high resistance.



PRODUCT CODE	INTERNAL CODE	CHARACTERISTICS							
		L (mm)	S (mm)	h (mm)	R (mm)	GC st. (mm)	GC sid. (mm)	Work. Load Max N (21°C)	Weight kg/m
LFA 879 K325	6.13.040	82.5	4.8	15.2	400	44.5	41.4	2100	0.93
LFA 879 K330	6.13.042	83.8	4.8	15.2	400	44.5	41.4	2100	0.97
LFA 879 K350	6.13.060	88.9	4.8	15.2	400	44.5	41.4	2100	1.05
LFA 879 K450	6.13.080	114.3	4.8	15.2	400	44.5	41.4	2100	1.10

- Standard shipping lengths = 80 pitches = 10 feet = 3,048 metres.
- These chains can be supplied either with pins in austenitic stainless steel, work hardened, highly wear resistant or with pins in thermoplastic resin.

thermoplastic sideflexing chains

880 TAB SERIES

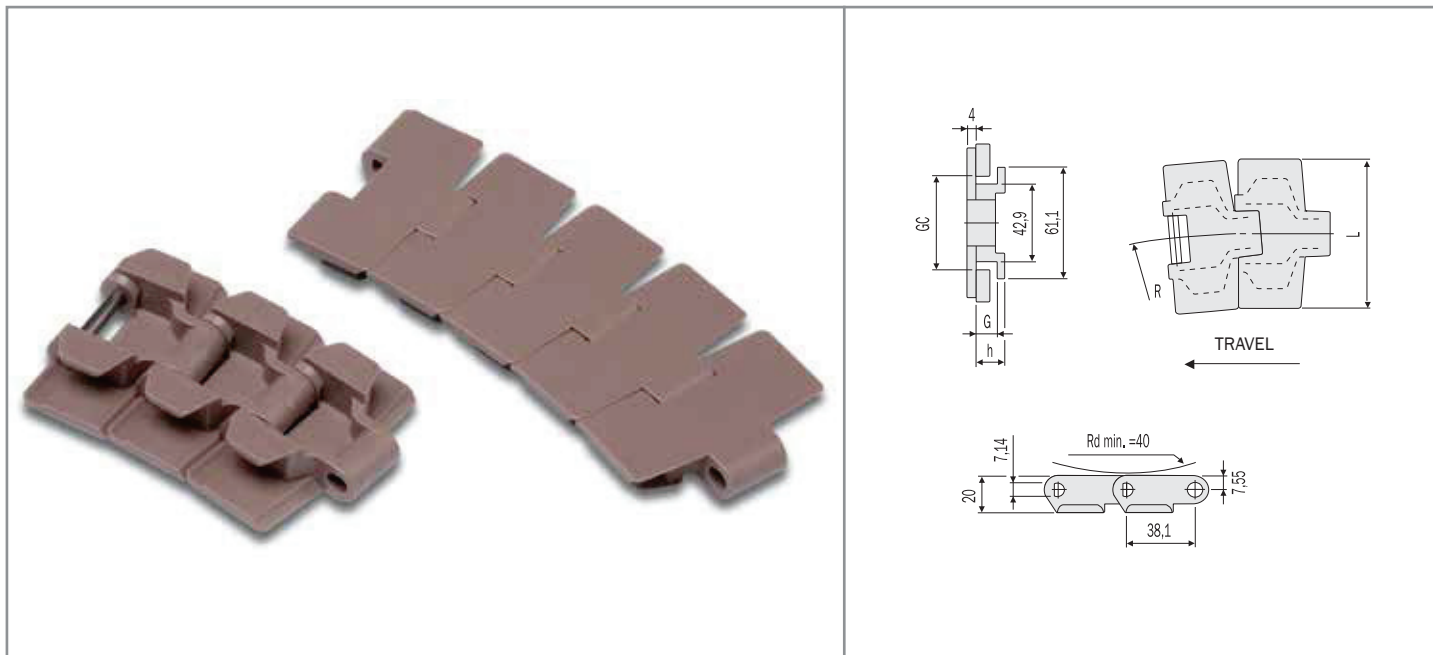

D 880 TAB - ACETAL RESIN

- Plates in self-lubricating acetal resin, grey-coloured.
- Pins in special chrome-nickel stainless steel, work hardened for high resistance.



PRODUCT CODE	INTERNAL CODE	CHARACTERISTICS							
		L (mm)	h (mm)	R (mm)	G (mm)	GC st. (mm)	GC sid. (mm)	Work. Load Max N (21°C)	Weight kg/m
D 880 TAB K325	6.02.041	82.5	16	400	11.5	46	44.2	2100	0.94
D 880 TAB K350	6.02.061	88.9	16	400	11.5	46	44.2	2100	1.01
D 880 TAB K450	6.02.081	114.3	16	400	11.5	46	44.2	2100	1.08
D 880 TAB K750	6.02.111	190.5	16	400	11.5	46	44.2	2100	1.48

- Standard shipping lengths = 80 pitches = 10 feet = 3,048 metres.
- The above-mentioned chains can also be produced in acetal resin, white-coloured.
- These chains can be supplied either with pins in austenitic stainless steel, work hardened, highly wear resistant, or with pins in thermoplastic resin.

LFA 880 TAB - LOW FRICTION ACETAL RESIN

- Plates in self-lubricating low friction acetal resin, light brown-coloured.
- Pins in special chrome-nickel stainless steel, work hardened for high resistance.



PRODUCT CODE	INTERNAL CODE	CHARACTERISTICS							
		L (mm)	h (mm)	R (mm)	G (mm)	GC st. (mm)	GC sid. (mm)	Work. Load Max N (21°C)	Weight kg/m
LFA 880 TAB K250	6.12.021	63.5	16	400	11.5	46	44.2	2100	0.80
LFA 880 TAB K325	6.12.041	82.5	16	400	11.5	46	44.2	2100	0.94
LFA 880 TAB K330	6.12.042	83.8	16	400	11.5	46	44.2	2100	0.96
LFA 880 TAB K343	6.12.043	87.0	16	400	11.5	46	44.2	2100	0.99
LFA 880 TAB K350	6.12.061	88.9	16	400	11.5	46	44.2	2100	1.01
LFA 880 TAB K450	6.12.081	114.3	16	400	11.5	46	44.2	2100	1.08
LFA 880 TAB K600	6.12.101	152.4	16	400	11.5	46	44.2	2100	1.28
LFA 880 TAB K750	6.12.111	190.5	16	400	11.5	46	44.2	2100	1.48

- Standard shipping lengths = 80 pitches = 10 feet = 3,048 metres.
- These chains can be supplied either with pins in austenitic stainless steel, work hardened, highly wear resistant, or with pins in thermoplastic resin.

SP 880 TAB - SUPER PERFORMANCE ACETAL RESIN

- Plates in self-lubricating very low friction acetal resin, dark grey-coloured.
- Pins in special chrome-nickel stainless steel, work hardened for high resistance.



PRODUCT CODE	INTERNAL CODE	CHARACTERISTICS							
		L (mm)	h (mm)	R (mm)	G (mm)	GC st. (mm)	GC sid. (mm)	Work. Load Max N (21°C)	Weight kg/m
SP 880 TAB K250	6.22.021	63.5	16	400	11.5	46	44.2	2100	0.80
SP 880 TAB K325	6.22.041	82.5	16	400	11.5	46	44.2	2100	0.94
SP 880 TAB K343	6.22.043	87.0	16	400	11.5	46	44.2	2100	0.99
SP 880 TAB K350	6.22.061	88.9	16	400	11.5	46	44.2	2100	1.01
SP 880 TAB K450	6.22.081	114.3	16	400	11.5	46	44.2	2100	1.08
SP 880 TAB K600	6.22.101	152.4	16	400	11.5	46	44.2	2100	1.28
SP 880 TAB K750	6.22.111	190.5	16	400	11.5	46	44.2	2100	1.48

AK 880 TAB - HIGH WEAR RESISTANT ACETAL RESIN

- Plates in a very special acetal resin with aramidic fibers, dark grey-coloured.
- Pins in special chrome-nickel stainless steel, work hardened for high resistance.



PRODUCT CODE	INTERNAL CODE	CHARACTERISTICS							
		L (mm)	h (mm)	R (mm)	G (mm)	GC st. (mm)	GC sid. (mm)	Work. Load Max N (21°C)	Weight kg/m
AK 880 TAB K250	6.82.021	63.5	16	400	11.5	46	44.2	2100	0.80
AK 880 TAB K325	6.82.041	82.5	16	400	11.5	46	44.2	2100	0.94
AK 880 TAB K343	6.82.043	87.0	16	400	11.5	46	44.2	2100	0.99
AK 880 TAB K350	6.82.061	88.9	16	400	11.5	46	44.2	2100	1.01
AK 880 TAB K450	6.82.081	114.3	16	400	11.5	46	44.2	2100	1.08
AK 880 TAB K600	6.82.101	152.4	16	400	11.5	46	44.2	2100	1.28
AK 880 TAB K750	6.82.111	190.5	16	400	11.5	46	44.2	2100	1.48

AS 880 TAB - ANTISTATIC ACETAL RESIN

- Plates in antistatic conductive acetal resin, black-coloured.
- Pins in special chrome-nickel stainless steel, work hardened for high resistance.

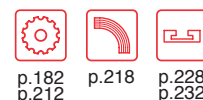

PRODUCT CODE	INTERNAL CODE	CHARACTERISTICS							
		L (mm)	h (mm)	R (mm)	G (mm)	GC st. (mm)	GC sid. (mm)	Work. Load Max N (21°C)	Weight kg/m
AS 880 TAB K325	6.32.041	82.5	16	400	11.5	46	44.2	2100	0.74
AS 880 TAB K350	6.32.061	88.9	16	400	11.5	46	44.2	2100	1.81
AS 880 TAB K450	6.32.081	114.3	16	400	11.5	46	44.2	2100	1.88
AS 880 TAB K750	6.32.111	190.5	16	400	11.5	46	44.2	2100	1.28

WRX 880 TAB - WEAR RESISTANT POLYAMIDE COMPOSITE

- Plates in thermoplastic wear resistant polyamide composite, black-coloured.
- Pins in special chrome-nickel stainless steel, work hardened for high resistance.

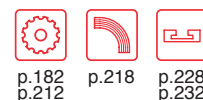

PRODUCT CODE	INTERNAL CODE	CHARACTERISTICS							
		L (mm)	h (mm)	R (mm)	G (mm)	GC st. (mm)	GC sid. (mm)	Work. Load Max N (21°C)	Weight kg/m
WRX 880 TAB K325	6.52.041	82.5	16	400	11.5	46	44.2	2100	0.94
WRX 880 TAB K350	6.52.061	88.9	16	400	11.5	46	44.2	2100	1.01
WRX 880 TAB K450	6.52.081	114.3	16	400	11.5	46	44.2	2100	1.08
WRX 880 TAB K750	6.52.111	190.5	16	400	11.5	46	44.2	2100	1.48

- Standard shipping lengths = 80 pitches = 10 feet = 3,048 metres.
- These chains can be supplied either with pins in austenitic stainless steel, work hardened, highly wear resistant, or with pins in thermoplastic resin.
- The above-mentioned chains can also be produced in special acetal resin, with aramidic fibers yellow-coloured. (FOR AK 880 TAB)

PPB 880 TAB - CHEMICAL RESIST. REINFORCED POLYPROPYLENE



p.182
p.212



p.218



p.228
p.232

- Plates in chemical resistant reinforced polypropylene, white-coloured.
- Pins in chrome-nickel austenitic stainless steel (18% Chrome – 8% Nickel), work hardened for high resistance.

PRODUCT CODE	INTERNAL CODE	CHARACTERISTICS							
		L (mm)	h (mm)	R (mm)	G (mm)	GC st. (mm)	GC sid. (mm)	Work. Load Max N (21°C)	Weight kg/m
PPB 880 TAB K325	6.42.041	82.5	16	400	11.5	46	44.2	1900	0.74
PPB 880 TAB K350	6.42.061	88.9	16	400	11.5	46	44.2	1900	0.81
PPB 880 TAB K450	6.42.081	114.3	16	400	11.5	46	44.2	1900	0.88
PPB 880 TAB K750	6.42.111	190.5	16	400	11.5	46	44.2	1900	1.28

- Standard shipping lengths = 80 pitches = 10 feet = 3,048 metres.
- These chains can be supplied either with pins in austenitic stainless steel 316 series, work hardened, highly wear resistant, or with pins in reinforced polypropylene.
- PPB chains dimensions are larger than those indicated in the drawing. To know dimensions refer to our Technical Department.

PBT 880 TAB - EXTRA PERFORMANCE POLYESTER RESIN



p.182
p.212



p.218



p.228
p.232

- Plates in low friction polyester resin, green-coloured.
- Pins in special chrome-nickel stainless steel, work hardened for high resistance.

PRODUCT CODE	INTERNAL CODE	CHARACTERISTICS							
		L (mm)	h (mm)	R (mm)	G (mm)	GC st. (mm)	GC sid. (mm)	Work. Load Max N (21°C)	Weight kg/m
PBT 880 TAB K325	6.72.041	82.5	16	400	11.5	46	44.2	2100	0.94
PBT 880 TAB K350	6.72.061	88.9	16	400	11.5	46	44.2	2100	1.01
PBT 880 TAB K450	6.72.081	114.3	16	400	11.5	46	44.2	2100	1.08
PBT 880 TAB K750	6.72.111	190.5	16	400	11.5	46	44.2	2100	1.48

- Standard shipping lengths = 80 pitches = 10 feet = 3,048 metres.
- These chains can be supplied either with pins in austenitic stainless steel, work hardened, highly wear resistant, or with pins in thermoplastic resin.
- The above-mentioned chains can also be produced in extra performance polyester resin, white-coloured.

thermoplastic sideflexing chains

879 TAB SERIES

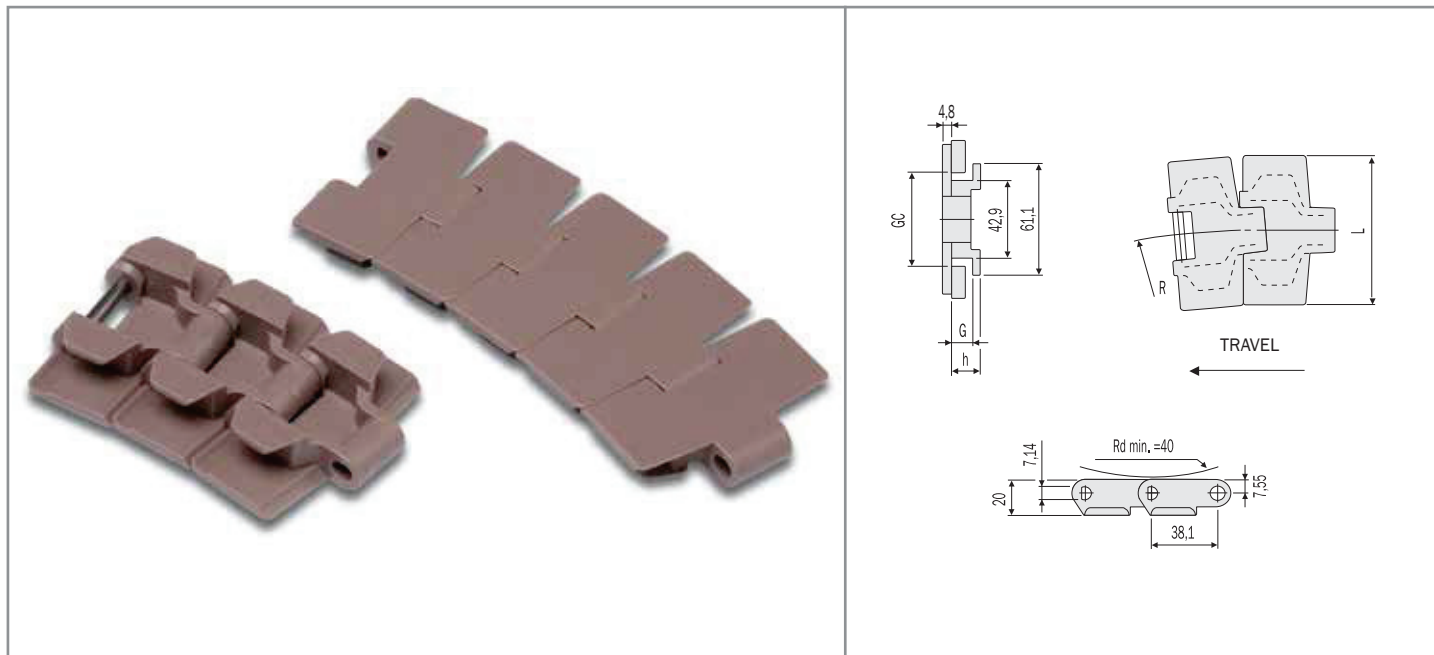

LFA 879 TAB - LOW FRICTION ACETAL RESIN

TOP PLATE THICKNESS 4,8mm

- Plates in self-lubricating low friction acetal resin, light brown-coloured.
- Pins in special chrome-nickel stainless steel, work hardened for high resistance.



p.182
p.212



p.218



p.228
p.232

PRODUCT CODE	INTERNAL CODE	CHARACTERISTICS							
		L (mm)	h (mm)	R (mm)	G (mm)	GC st. (mm)	GC sid. (mm)	Work. Load Max N (21°C)	Weight kg/m
LFA 879 TAB K325	6.13.041	82.5	15.2	400	11	46	44.2	2100	0.98
LFA 879 TAB K330	6.13.242	83.8	15.2	400	11	46	44.2	2100	1.02
LFA 879 TAB K350	6.13.061	88.9	15.2	400	11	46	44.2	2100	1.10
LFA 879 TAB K450	6.13.081	114.3	15.2	400	11	46	44.2	2100	1.14

- Standard shipping lengths = 80 pitches = 10 feet = 3,048 metres.
- These chains can be supplied either with pins in austenitic stainless steel, work hardened, highly wear resistant, or with pins in thermoplastic resin.

SP 879 TAB - SUPER PERFORMANCE ACETAL RESIN

TOP PLATE THICKNESS 4,8mm

- Plates in self-lubricating very low friction acetal resin, dark grey-coloured.
- Pins in special chrome-nickel stainless steel, work hardened for high resistance.



p.182
p.212



p.218



p.228
p.232

PRODUCT CODE	INTERNAL CODE	CHARACTERISTICS							
		L (mm)	h (mm)	R (mm)	G (mm)	GC st. (mm)	GC sid. (mm)	Work. Load Max N (21°C)	Weight kg/m
SP 879 TAB K325	6.23.041	82.5	15.2	400	11	46	44.2	2100	0.98
SP 879 TAB K330	6.23.242	83.8	15.2	400	11	46	44.2	2100	1.02
SP 879 TAB K350	6.23.061	88.9	15.2	400	11	46	44.2	2100	1.10
SP 879 TAB K450	6.23.081	114.3	15.2	400	11	46	44.2	2100	1.14

- Standard shipping lengths = 80 pitches = 10 feet = 3,048 metres.
- These chains can be supplied either with pins in austenitic stainless steel, work hardened, highly wear resistant, or with pins in thermoplastic resin.

thermoplastic sideflexing chains

880 BO / 879 BO SERIES - REDUCED SIDEFLEXING RADIUS R190

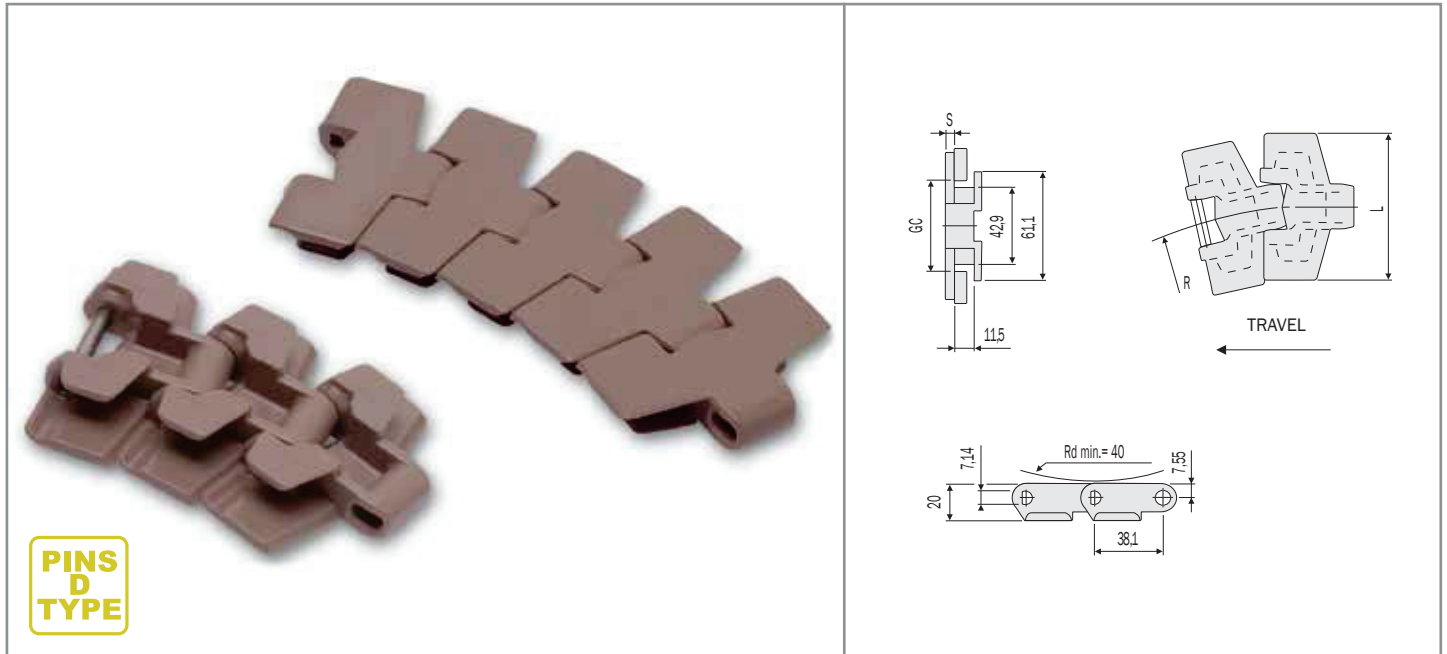

**PINS
D
TYPE**

LFA 880 BO - LOW FRICTION ACETAL RESIN

- Plates in self-lubricating low friction acetal resin, light brown-coloured.
- Pins in special chrome-nickel stainless steel, work hardened for high resistance.



PRODUCT CODE	INTERNAL CODE	CHARACTERISTICS						
		L (mm)	S (mm)	R (mm)	GC st. (mm)	GC sid. (mm)	Work. Load Max N (21°C)	Weight kg/m
LFA 880 BO K250	6.19.020	63.5	4	190	46	44.2	1680	0.88
LFA 880 BO K325	6.19.040	82.5	4	190	46	44.2	1680	0.96
LFA 880 BO K450	6.19.080	114.3	4	190	46	44.2	1680	1.04

- Standard shipping lengths = 80 pitches = 10 feet = 3,048 metres.
- These chains can be supplied either with pins in austenitic stainless steel, work hardened, highly wear resistant, or with pins in thermoplastic resin.

LFA 879 BO - LOW FRICTION ACETAL RESIN

TOP PLATE THICKNESS 4,8mm

- Plates in self-lubricating low friction acetal resin, light brown-coloured.
- Pins in special chrome-nickel stainless steel, work hardened for high resistance.



PRODUCT CODE	INTERNAL CODE	CHARACTERISTICS						
		L (mm)	S (mm)	R (mm)	GC st. (mm)	GC sid. (mm)	Work. Load Max N (21°C)	Weight kg/m
LFA 879 BO K325	6.17.040	82.5	4.8	190	46	44.2	2100	1.08
LFA 879 BO K450	6.17.080	114.3	4.8	190	46	44.2	2100	1.23

- Standard shipping lengths = 80 pitches = 10 feet = 3,048 metres.
- These chains can be supplied either with pins in austenitic stainless steel, work hardened, highly wear resistant, or with pins in thermoplastic resin.

thermoplastic sideflexing chains

878 BO SERIES - REDUCED SIDEFLEXING RADIUS R190

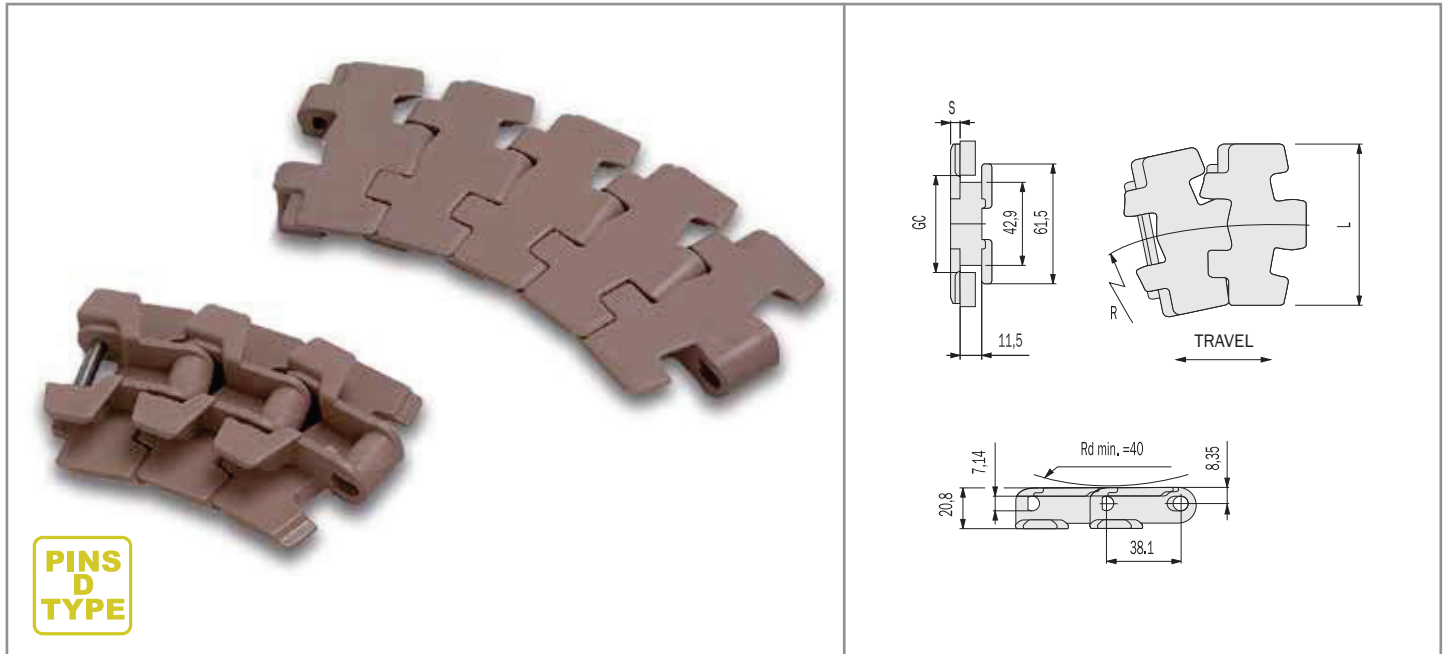

LFA 878 BO - LOW FRICTION ACETAL RESIN

TOP PLATE THICKNESS 4,8mm

- Plates in self-lubricating low friction acetal resin, light brown-coloured.
- Pins in special chrome-nickel stainless steel, work hardened for high resistance.



p.182
p.208
p.212

p.218

p.228
p.232

PRODUCT CODE	INTERNAL CODE	CHARACTERISTICS						
		L (mm)	S (mm)	R (mm)	GC st. (mm)	GC sid. (mm)	Work. Load Max N (21°C)	Weight kg/m
LFA 878 BO K325	6.17.041	82.5	4.8	190	46	44.2	2100	1.08
LFA 878 BO K450	6.17.081	114.3	4.8	190	46	44.2	2100	1.20

- Standard shipping lengths = 80 pitches = 10 feet = 3,048 metres.
- These chains can be supplied either with pins in austenitic stainless steel, work hardened, highly wear resistant, or with pins in thermoplastic resin.

SP 878 BO - SUPER PERFORMANCE ACETAL RESIN

TOP PLATE THICKNESS 4,8mm

- Plates in self-lubricating very low friction acetal resin, dark grey-coloured.
- Pins in special chrome-nickel stainless steel, work hardened for high resistance.



p.182
p.208
p.212

p.218

p.228
p.232

PRODUCT CODE	INTERNAL CODE	CHARACTERISTICS						
		L (mm)	S (mm)	R (mm)	GC st. (mm)	GC sid. (mm)	Work. Load Max N (21°C)	Weight kg/m
SP 878 BO K325	6.27.041	82.5	4.8	190	46	44.2	2100	1.08
SP 878 BO K450	6.27.081	114.3	4.8	190	46	44.2	2100	1.20

- Standard shipping lengths = 80 pitches = 10 feet = 3,048 metres.
- These chains can be supplied either with pins in austenitic stainless steel, work hardened, highly wear resistant, or with pins in thermoplastic resin.

thermoplastic sideflexing chains

ON MAGNETIC TRACKS - 880 M / 879 M SERIES



LFA 880 M - LOW FRICTION ACETAL RESIN

- Plates in self-lubricating low friction acetal resin, light brown-coloured.
- Pins in special stainless steel, 400 series, work hardened, magnetic, highly wear resistant.



PRODUCT CODE	INTERNAL CODE	CHARACTERISTICS						
	REDUCED PLATE GAP (*)	L (mm)	S (mm)	R (mm)	GC st. (mm)	GC sid. (mm)	Work. Load Max N (21°C)	Weight kg/m
LFA 880 M K325 (*)	6.18.040	82.5	4	500	44	44	2100	1.03
LFA 880 M K330 (*)	6.18.042	83.8	4	500	44	44	2100	1.06
LFA 880 M K350	6.18.060	88.9	4	457	44	44	2100	1.10
LFA 880 M K450	6.18.080	114.3	4	457	44	44	2100	1.16

SP 880 M - SUPER PERFORMANCE ACETAL RESIN

- Plates in self-lubricating very low friction acetal resin, dark grey-coloured.
- Pins in special stainless steel, 400 series, work hardened, magnetic, highly wear resistant.



PRODUCT CODE	INTERNAL CODE	CHARACTERISTICS						
	REDUCED PLATE GAP (*)	L (mm)	S (mm)	R (mm)	GC st. (mm)	GC sid. (mm)	Work. Load Max N (21°C)	Weight kg/m
SP 880 M K325 (*)	6.28.040	82.5	4	500	44	44	2100	1.03
SP 880 M K330 (*)	6.28.042	83.8	4	500	44	44	2100	1.06
SP 880 M K350	6.28.060	88.9	4	457	44	44	2100	1.10
SP 880 M K450	6.28.080	114.3	4	457	44	44	2100	1.16

LFA 879 M - LOW FRICTION ACETAL RESIN

TOP PLATE THICKNESS 4,8mm

- Plates in self-lubricating low friction acetal resin, light brown-coloured.
- Pins in special stainless steel, 400 series, work hardened, magnetic, highly wear resistant.



PRODUCT CODE	INTERNAL CODE	CHARACTERISTICS						
	REDUCED PLATE GAP (*)	L (mm)	S (mm)	R (mm)	GC st. (mm)	GC sid. (mm)	Work. Load Max N (21°C)	Weight kg/m
LFA 879 M K325 (*)	6.16.040	82.5	4.8	500	44	44	2100	1.08
LFA 879 M K450	6.16.080	114.3	4.8	457	44	44	2100	1.24

- Standard shipping lengths = 80 pitches = 10 feet = 3,048 metres.

thermoplastic sideflexing chains

882 TAB SERIES

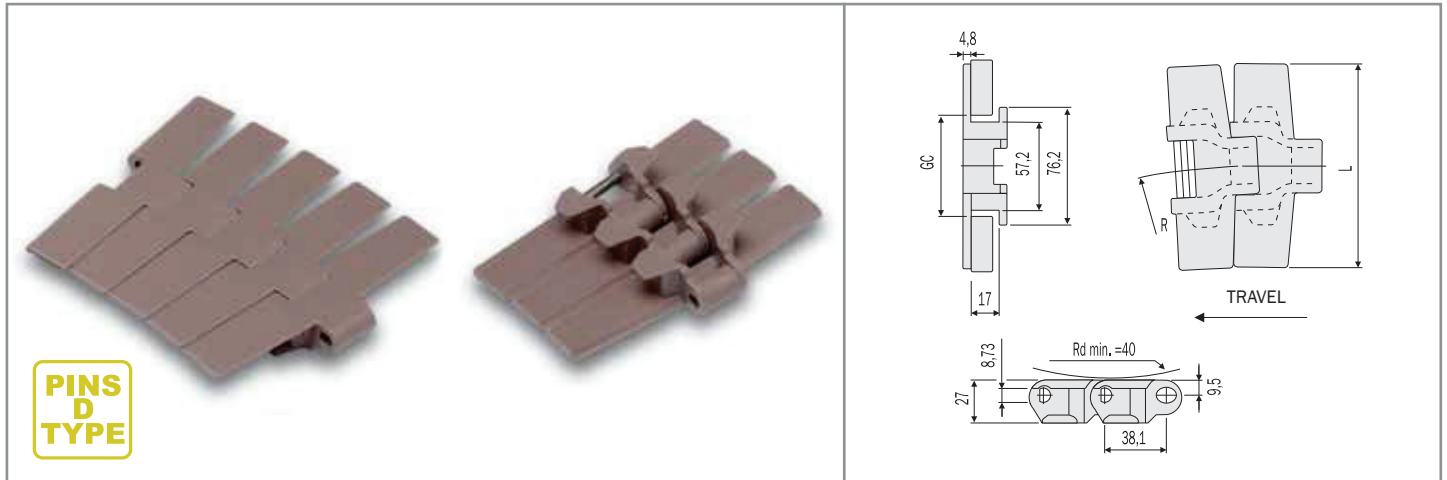

LFA 882 TAB - LOW FRICTION ACETAL RESIN

- Plates in self-lubricating low friction acetal resin, light brown-coloured.
- Pins in special chrome-nickel stainless steel, work hardened for high resistance.



PRODUCT CODE	INTERNAL CODE	CHARACTERISTICS					
		Width L (mm)	Radius R (mm)	GC st. (mm)	GC sid. (mm)	Working Load Max N (21°C)	Weight kg/m
LFA 882 TAB K450	6.15.081	114.3	610	60	58	3830	1.98
LFA 882 TAB K750	6.15.111	190.5	610	60	58	3830	2.43
LFA 882 TAB K1000	6.15.121	254.0	610	60	58	3830	2.87
LFA 882 TAB K1200	6.15.131	304.8	610	60	58	3830	3.41

SP 882 TAB - SUPER PERFORMANCE ACETAL RESIN

- Plates in self-lubricating very low friction acetal resin, dark grey-coloured.
- Pins in special chrome-nickel stainless steel, work hardened for high resistance.

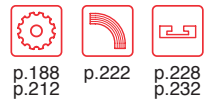

PRODUCT CODE	INTERNAL CODE	CHARACTERISTICS					
		Width L (mm)	Radius R (mm)	GC st. (mm)	GC sid. (mm)	Working Load Max N (21°C)	Weight kg/m
SP 882 TAB K450	6.25.081	114.3	610	60	58	3830	1.98
SP 882 TAB K750	6.25.111	190.5	610	60	58	3830	2.43
SP 882 TAB K1000	6.25.121	254.0	610	60	58	3830	2.87
SP 882 TAB K1200	6.25.131	304.8	610	60	58	3830	3.41

PPB 882 TAB - CHEMICAL RESIST. REINFORCED POLYPROPYLENE

- Plates in chemical resistant reinforced polypropylene, white-coloured.
- Pins in chrome-nickel austenitic stainless steel (18% Chrome – 8% Nickel), work hardened for high resistance.

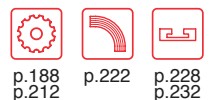

PRODUCT CODE	INTERNAL CODE	CHARACTERISTICS					
		Width L (mm)	Radius R (mm)	GC st. (mm)	GC sid. (mm)	Working Load Max N (21°C)	Weight kg/m
PPB 882 TAB K750*	6.45.111	190.5	610	60	58	3830	2.43
PPB 882 TAB K1000*	6.45.121	254.0	610	60	58	3830	2.87
PPB 882 TAB K1200*	6.45.131	304.8	650	60	58	3830	3.41

- Standard shipping lengths = 80 pitches = 10 feet = 3,048 metres.

- These chains can be supplied either with pins in austenitic stainless steel, work hardened, highly wear resistant, or with pins in thermoplastic resin.

* Size produced only upon request. Delivery conditions and terms to be agreed. These chains can be supplied either with pins in austenitic stainless steel, 316 series, work hardened, highly wear resistant, or with pins in reinforced polypropylene. (FOR PPB 882 TAB)

- PPB chains dimensions are larger than those indicated in the drawing. To know dimensions refer to our Technical Department.

thermoplastic sideflexing chains

882 BEVEL SERIES

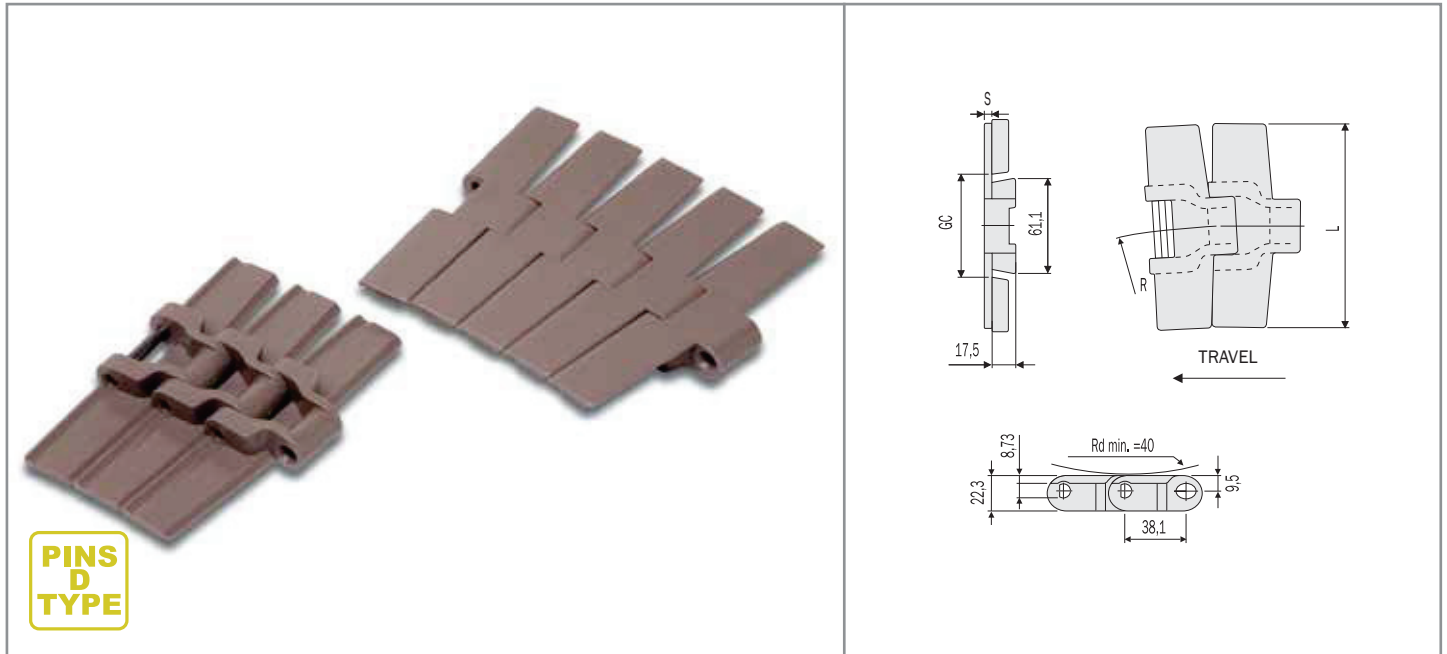

**PINS
D
TYPE**

LFA 882 - LOW FRICTION ACETAL RESIN

- Plates in self-lubricating low friction acetal resin, light brown-coloured.
- Pins in special chrome-nickel stainless steel, work hardened for high resistance.



p.188
p.212



p.223



p.229
p.232

PRODUCT CODE		INTERNAL CODE		CHARACTERISTICS					
		Width L (mm)	S (mm)	R (mm)	GC st. (mm)	GC sid. (mm)	Work. Load Max N (21°C)	Weight kg/m	
LFA 882 K450	6.15.080	114.3	4.8	610	61,9	58	3830	1.94	
LFA 882 K750	6.15.110	190.5	4.8	610	61,9	58	3830	2.38	
LFA 882 K1000	6.15.120	254.0	4.8	610	61,9	58	3830	2.83	
LFA 882 K1200	6.15.130	304.8	4.8	610	61,9	58	3830	2.75	

- Standard shipping lengths = 80 pitches = 10 feet = 3,048 metres.
- These chains can be supplied either with pins in austenitic stainless steel, work hardened, highly wear resistant, or with pins in thermoplastic resin.

thermoplastic sideflexing chains

ON MAGNETIC TRACKS - 882 M SERIES

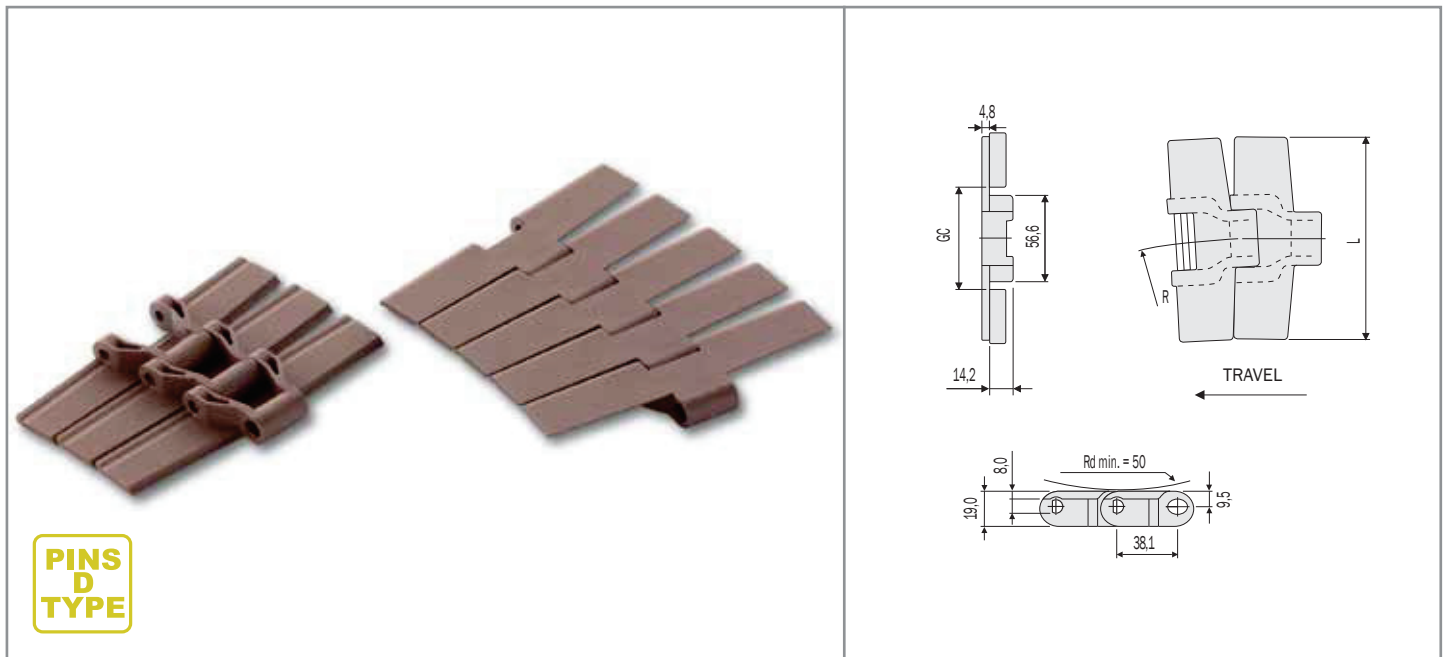

LFA 882 M - LOW FRICTION ACETAL RESIN

- Plates in self-lubricating low friction acetal resin, light brown-coloured.
- Pins in special stainless steel, 400 series, work hardened, magnetic, highly wear resistant.



p.188
p.212



p.107



p.230
p.232

PRODUCT CODE	INTERNAL CODE	CHARACTERISTICS				
		Width L (mm)	Radius R (mm)	GC (mm)	Working Load Max N (21°C)	Weight kg/m
LFA 882 M K750	6.18.175	190.5	610	60	3830	2.16
LFA 882 M K1000	6.18.185	254.0	610	60	3830	2.45
LFA 882 M K1200	6.18.195	304.8	610	60	3830	2.70

- Standard shipping lengths = 80 pitches = 10 feet = 3,048 metres.

SP 882 M - SUPER PERFORMANCE ACETAL RESIN

- Plates in self-lubricating very low friction acetal resin, dark grey-coloured.
- Pins in special stainless steel, 400 series, work hardened, magnetic, highly wear resistant.



p.188
p.212



p.107



p.230
p.232

PRODUCT CODE	INTERNAL CODE	CHARACTERISTICS				
		Width L (mm)	Radius R (mm)	GC (mm)	Working Load Max N (21°C)	Weight kg/m
SP 882 M K750	6.28.175	190.5	610	60	3830	2.16
SP 882 M K1000	6.28.185	254.0	610	60	3830	2.45
SP 882 M K1200	6.28.195	304.8	610	60	3830	2.70

- Standard shipping lengths = 80 pitches = 10 feet = 3,048 metres.

thermoplastic straight running chains

DOUBLE HINGE - LBP 821 SERIES

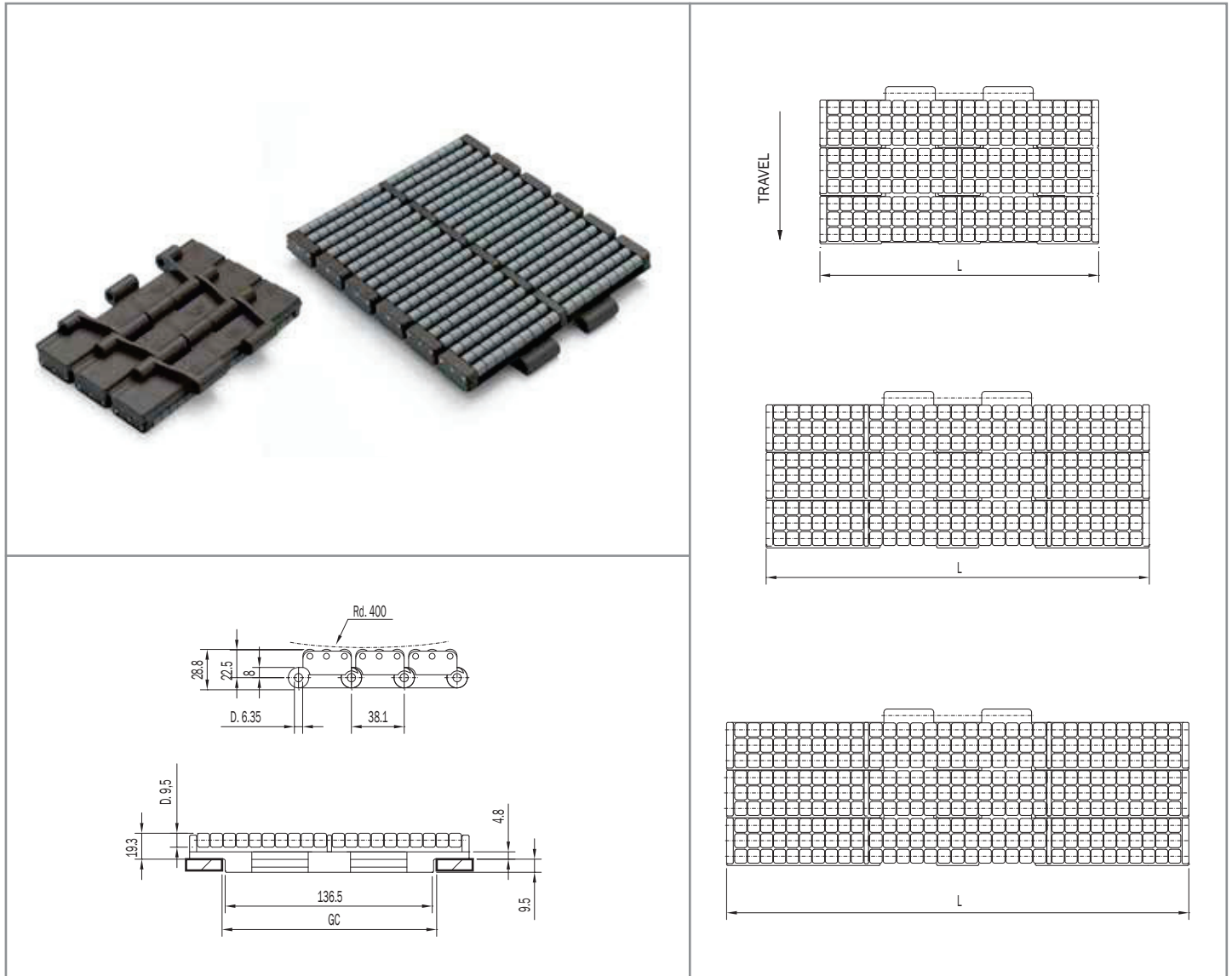

ADVANTAGES

- High breaking load.
- Rollers are made in special material for low friction and high wear resistance.
- Very low back-line pressure.
- Extremely quite running of the rollers.
- Pins rollers support of 5 mm diameter, plugged-in and locked at the ends.

LBP 821 - SUPER PERFORMANCE ACETAL RESIN

- Plates in self-lubricating very low friction acetal resin, dark grey-coloured.
- Rollers are made of special wear resistance acetal resin, light-grey coloured.
- Pins in special chrome-nickel stainless steel, work hardened for high resistance.



p.176
p.211



p.230
p.232

PRODUCT CODE	INTERNAL CODE	CHARACTERISTICS			
		Width L (mm)	GC (mm)	Working Load Max N (21°C)	Weight kg/m
LBP 821 K750	6.24.110LBP	190.5	140	2680	5.52
LBP 821 K1000	6.24.120LBP	254.0	140	2680	6.9
LBP 821 K1200	6.24.130LBP	304.8	140	2680	8.0

- Standard shipping lengths = 40 pitches = 5 feet = 1,524 metres.

thermoplastic straight running chains

SINGLE REINFORCED HINGE - LBP 8257 SERIES

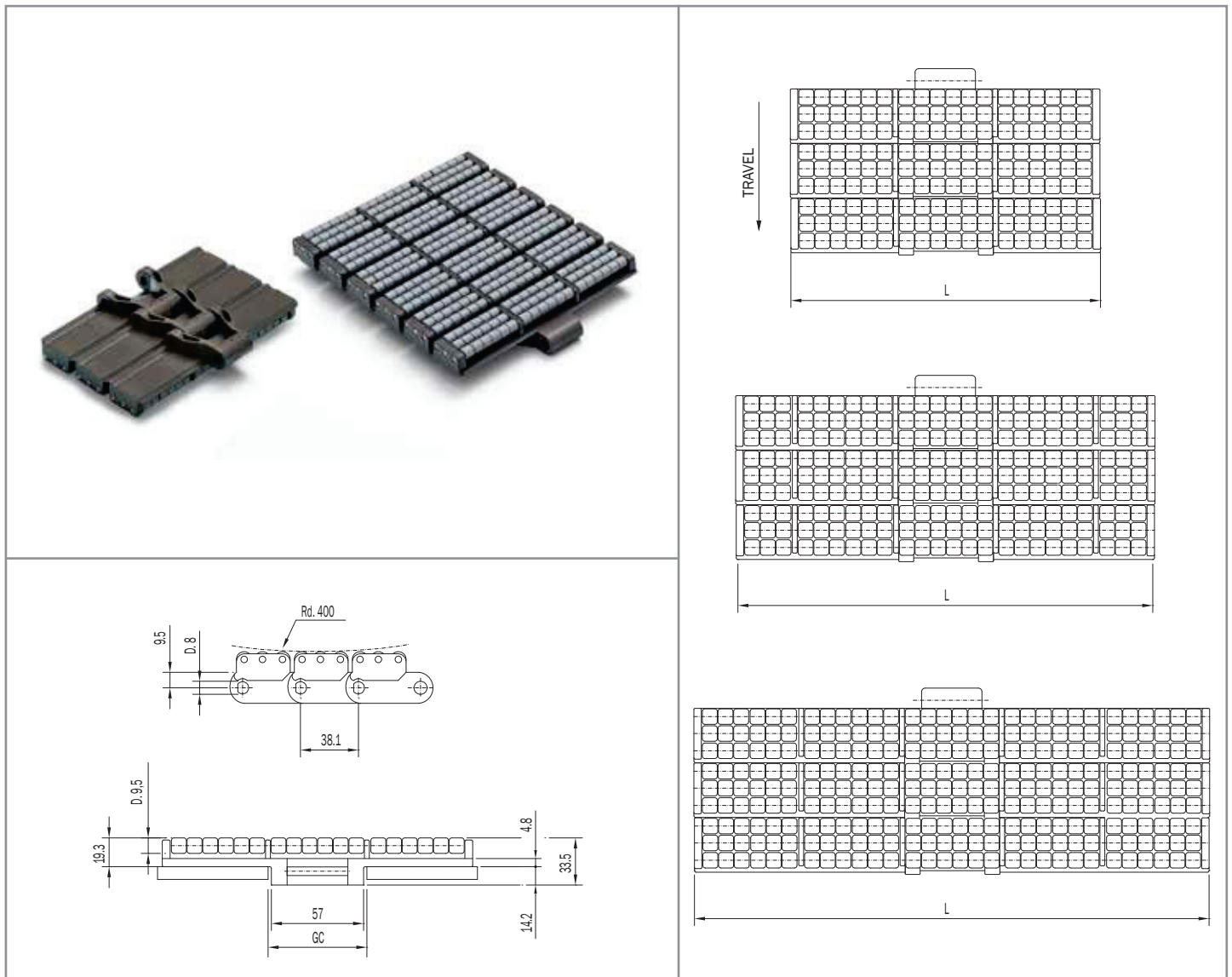

ADVANTAGES

- High breaking load.
- Rollers are made in special material for low friction and high wear resistance.
- Very low back-line pressure.
- Extremely quite running of the rollers.
- Pins rollers support of 5 mm diameter, plugged-in and locked at the ends.

LBP 8257 - SUPER PERFORMANCE ACETAL RESIN

- Plates in self-lubricating very low friction acetal resin, dark grey-coloured.
- Rollers are made of special wear resistance acetal resin, light-grey coloured.
- Pins in special stainless steel, 400 series, work hardened, magnetic, highly wear resistant.

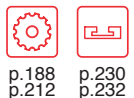

p.188 p.230
p.212 p.232

PRODUCT CODE	INTERNAL CODE	CHARACTERISTICS			
		Width L (mm)	GC (mm)	Working Load Max N (21°C)	Weight kg/m
LBP 8257 K750	6.20.175LBP	190.5	60	3830	5.65
LBP 8257 K1000	6.20.185LBP	254.0	60	3830	7.2
LBP 8257 K1200	6.20.195LBP	304.8	60	3830	8.1

- Standard shipping lengths = 40 pitches = 5 feet = 1,524 metres.

thermoplastic sideflexing chains

LBP 882 TAB SERIES

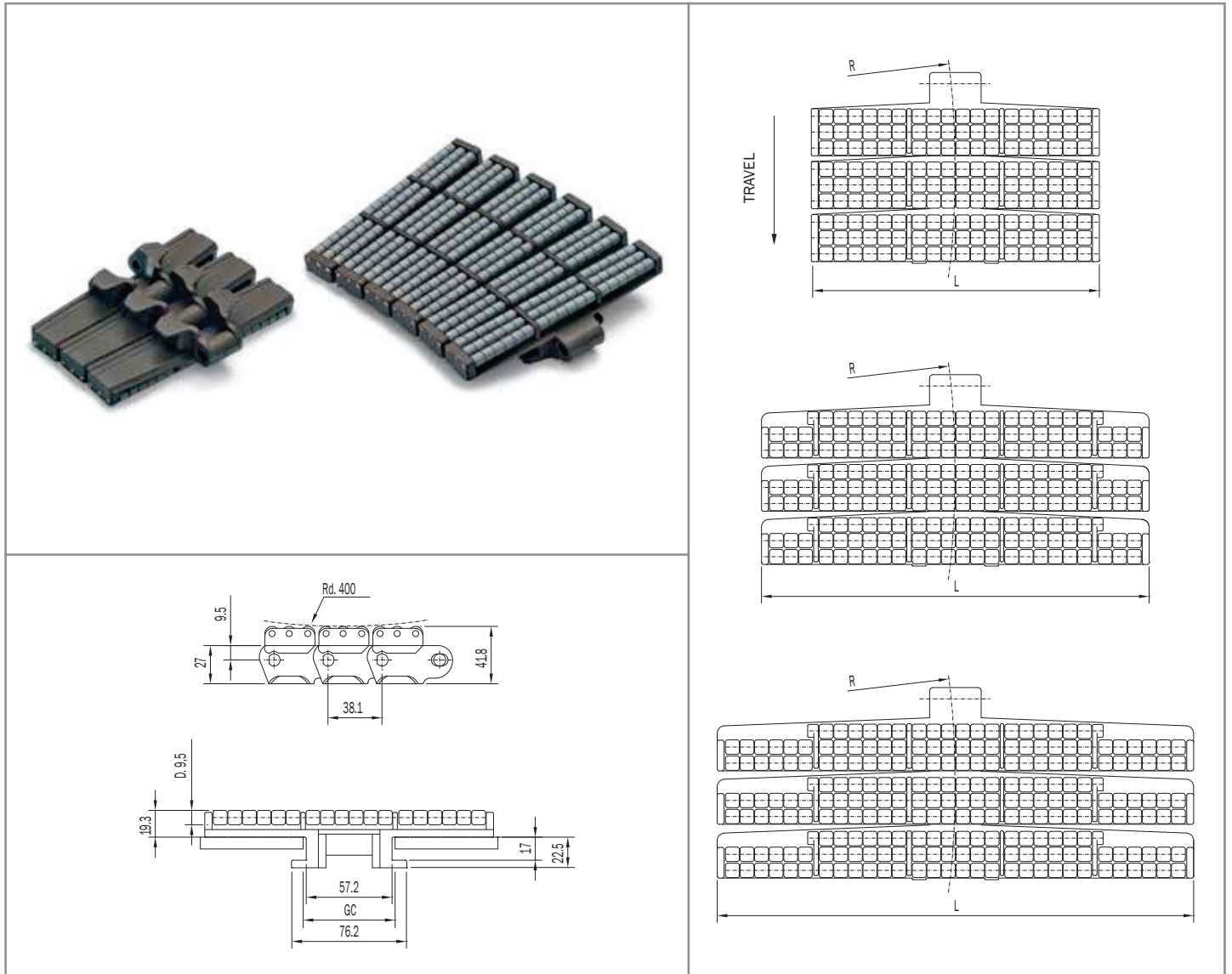

ADVANTAGES

- High breaking load.
- Rollers are made in special material for low friction and high wear resistance.
- Very low back-line pressure.
- Extremely quite running of the rollers.
- Pins rollers support of 5 mm diameter, plugged-in and locked at the ends.

LBP 882 TAB - SUPER PERFORMANCE ACETAL RESIN

- Plates in self-lubricating very low friction acetal resin, dark grey-coloured.
- Rollers are made of special wear resistance acetal resin, light-grey coloured.
- Pins in special chrome-nickel stainless steel, work hardened for high resistance.



p.188
p.212



p.222



p.230
p.232

PRODUCT CODE	INTERNAL CODE	CHARACTERISTICS				
		Width L (mm)	Radius R (mm)	GC (mm)	Working Load Max N (21°C)	Weight kg/m
LBP 882 TAB K750	6.25.111LBP	190.5	610	60	3830	4.7
LBP 882 TAB K1000	6.25.121LBP	254.0	610	60	3830	5.9
LBP 882 TAB K1200	6.25.131LBP	304.8	650	60	3830	6.5

- Standard shipping lengths = 40 pitches = 5 feet = 1,524 metres.

thermoplastic sideflexing chains

ON MAGNETIC TRACKS - LBP 882 M SERIES

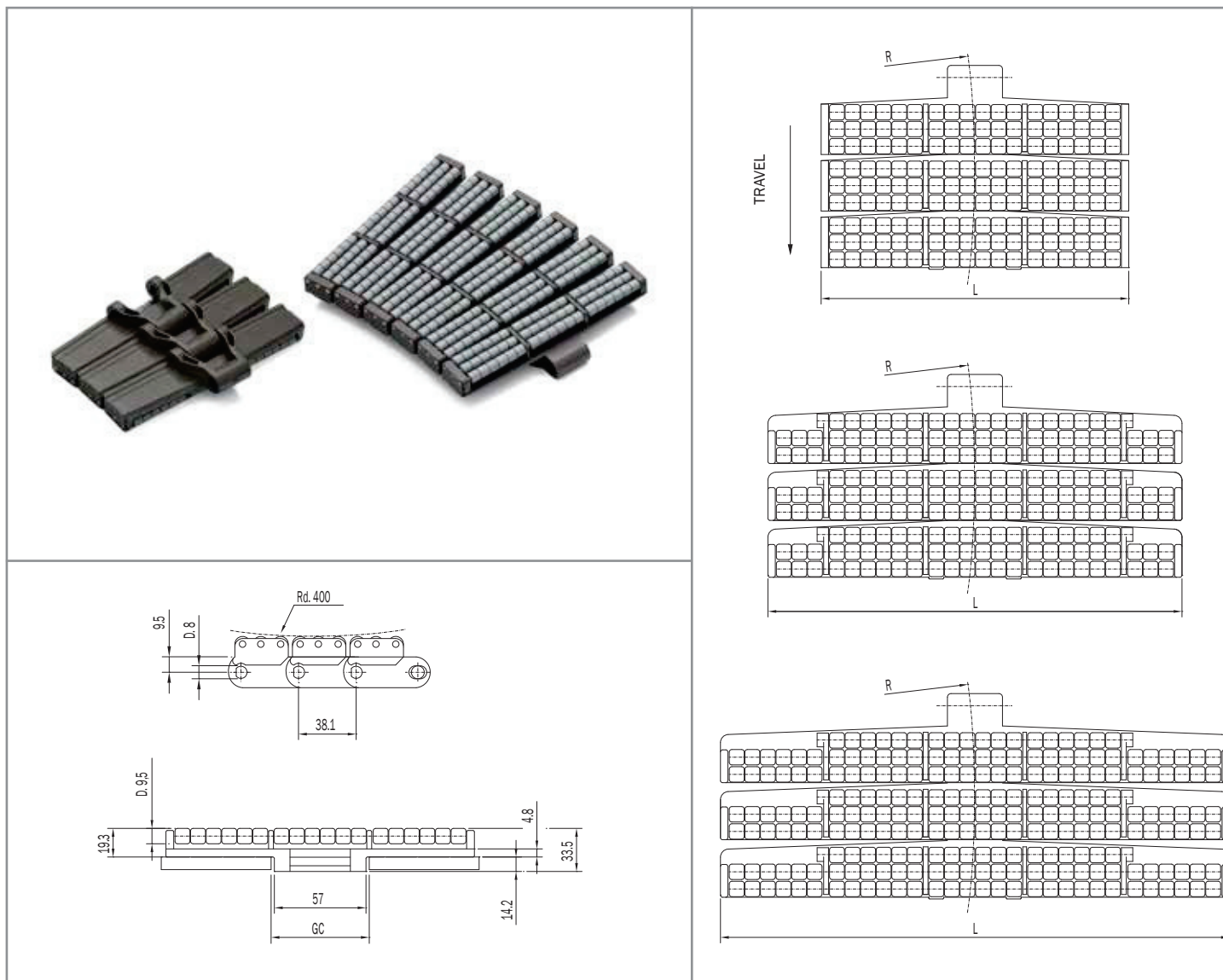

ADVANTAGES

- High breaking load.
- Rollers are made in special material for low friction and high wear resistance.
- Very low back-line pressure.
- Extremely quite running of the rollers.
- Pins rollers support of 5 mm diameter, plugged-in and locked at the ends.

LBP 882 M SERIES - SUPER PERFORMANCE ACETAL RESIN

- Plates in self-lubricating very low friction acetal resin, dark grey-coloured.
- Rollers are made of special wear resistance acetal resin, light-grey coloured.
- Pins in special stainless steel, 400 series, work hardened, magnetic, highly wear resistant.



p.188
p.212



p.107



p.230
p.232

PRODUCT CODE	INTERNAL CODE	CHARACTERISTICS				
		Width L (mm)	Radius R (mm)	GC (mm)	Working Load Max N (21°C)	Weight kg/m
LBP 882 M K750	6.28.175LBP	190.5	610	60	3830	3.90
LBP 882 M K1000	6.28.185LBP	254.0	610	60	3830	4.95
LBP 882 M K1200	6.28.195LBP	304.8	650	60	3830	5.85

- Standard shipping lengths = 40 pitches = 5 feet = 1,524 metres.

vacuum thermoplastic straight runn. chains

820 VACUUM SERIES

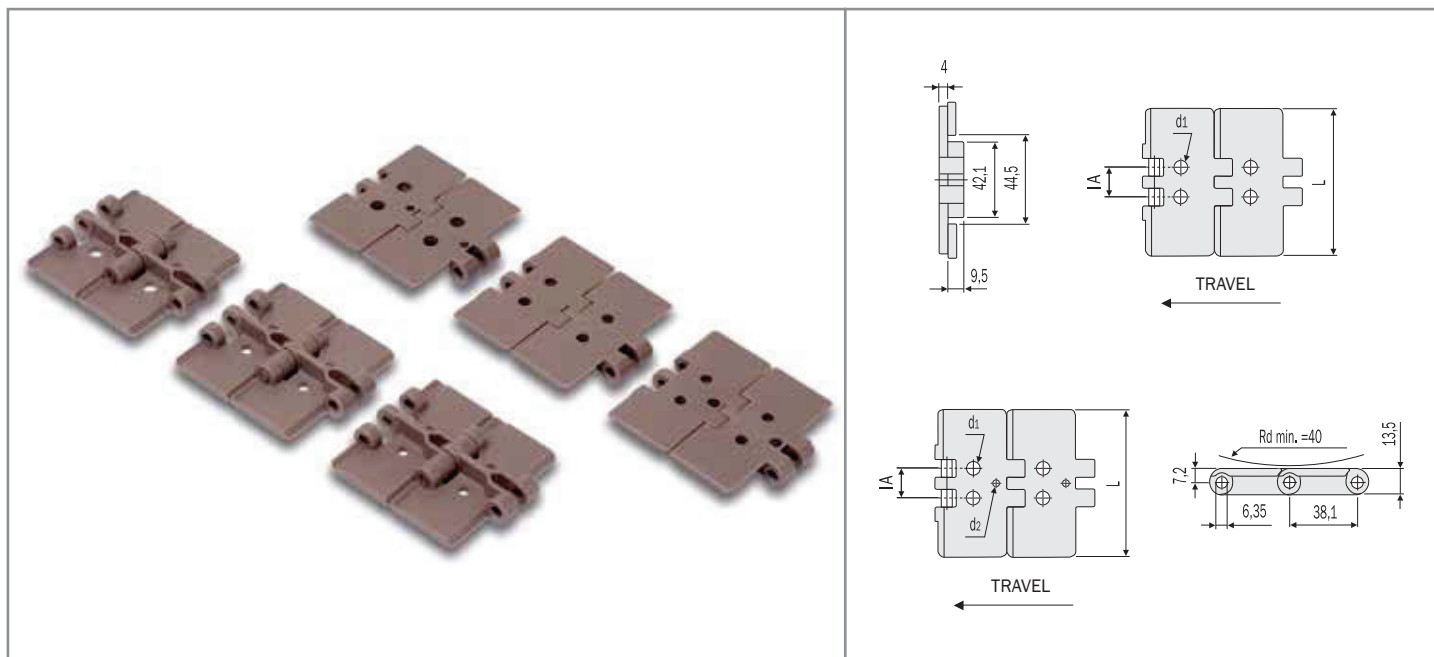

LFA 820 VACUUM - LOW FRICTION ACETAL RESIN

- Plates in self-lubricating low friction acetal resin, light brown-coloured, with 2 or 3 bores per link.
- Pins in special chrome-nickel stainless steel, work hardened for high resistance.



p.169
p.210



p.230
p.232

PRODUCT CODE	INTERNAL CODE	CHARACTERISTICS					
		Width L (mm)	Diam. bore d1 (mm)	Diam. bore d2 (mm)	IA* (mm)	Working Load Max N (21°C)	Weight kg/m
	B2 TWO BORES						
LFA 820 K325 B2	6.10.040.2	82.5	6.5	-	19	1230	0.83
LFA 820 K350 B2	6.10.060.2	88.9	4.0	-	45	1230	0.87
LFA 820 K450 B2 H30	6.10.080.2a	114.3	8.0	-	30	1230	1.03
LFA 820 K450 B2 H50	6.10.080.2b	114.3	8.0	-	50	1230	1.03
	B3 THREE BORES						
LFA 820 K325 B3	6.10.040.3	82.5	7.9	4.4	20	1230	0.83

* IA = Distance between centres.

- Standard shipping lengths = 80 pitches = 10 feet = 3,048 metres.

- These chains can be supplied either with pins in austenitic stainless steel, work hardened, highly wear resistant, or with pins in thermoplastic resin.

vacuum thermoplastic sideflexing chains

880 TAB VACUUM SERIES

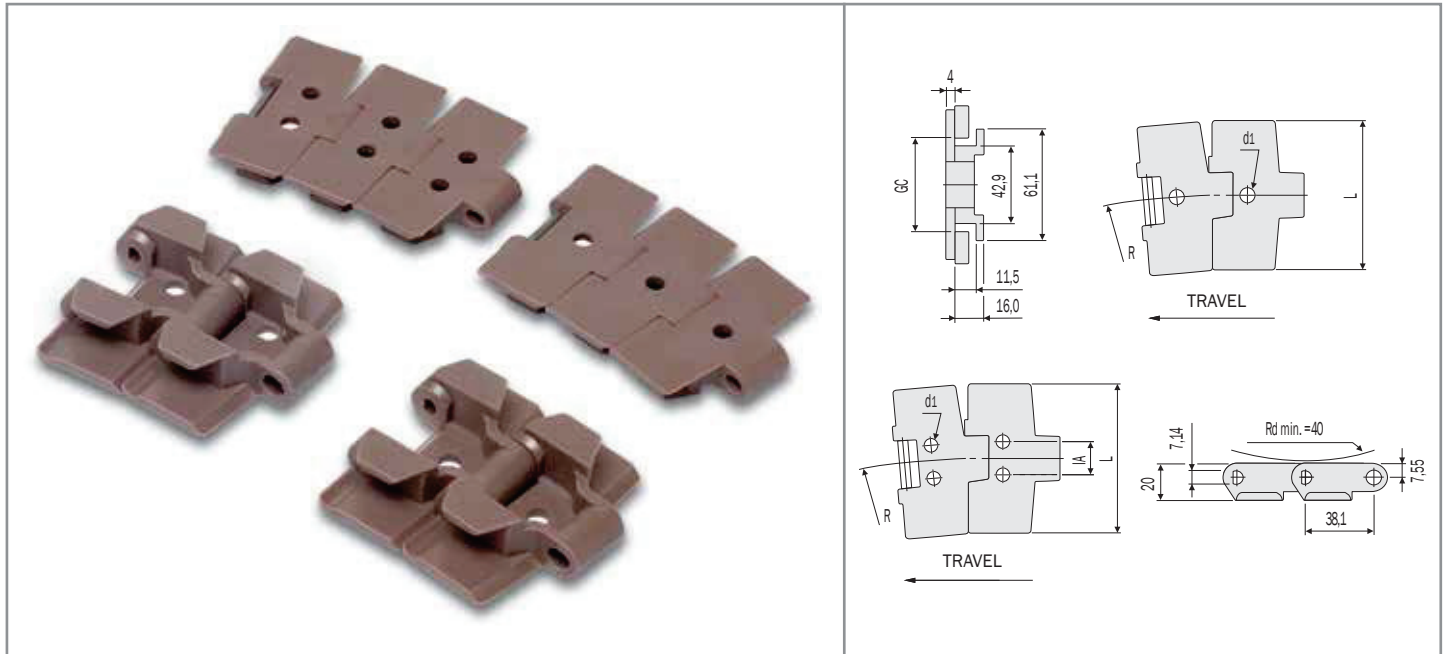

LFA 880 TAB VACUUM - LOW FRICTION ACETAL RESIN

- Plates in self-lubricating low friction acetal resin, light brown-coloured, with 1 or 2 bores per link.
- Pins in special chrome-nickel stainless steel, work hardened for high resistance.



p.182
p.212



p.218



p.230
p.232

PRODUCT CODE	INTERNAL CODE	CHARACTERISTICS							
		Width L (mm)	Diam. bore d1 (mm)	IA* (mm)	R (mm)	GC st. (mm)	GC sid. (mm)	Work. Load Max N (21°C)	Weight kg/m
	B1 ONE BORE								
LFA 880 TAB K325 B1...	6.12.041.1...	82.5	5 / 6 / 6.5 8 / 9.5 / 10	-	457	46	44.2	2100	0.94
	B2 TWO BORES								
LFA 880 TAB K325 B2...	6.12.041.2a	82.5	6.0	24	457	46	44.2	2100	0.94
	6.12.041.2b	82.5	8.0	20	457	46	44.2	2100	0.94
LFA 880 TAB K450 B2...	6.12.081.2a	114.3	6.0	24	610	46	44.2	2100	1.08

* IA = Distance between centres.

- Standard shipping lengths = 80 pitches = 10 feet = 3,048 metres.

- These chains can be supplied either with pins in austenitic stainless steel, work hardened, highly wear resistant, or with pins in thermoplastic resin.

straight running chains

WITH THERMOPLASTIC TOP PLATES - 843 SERIES

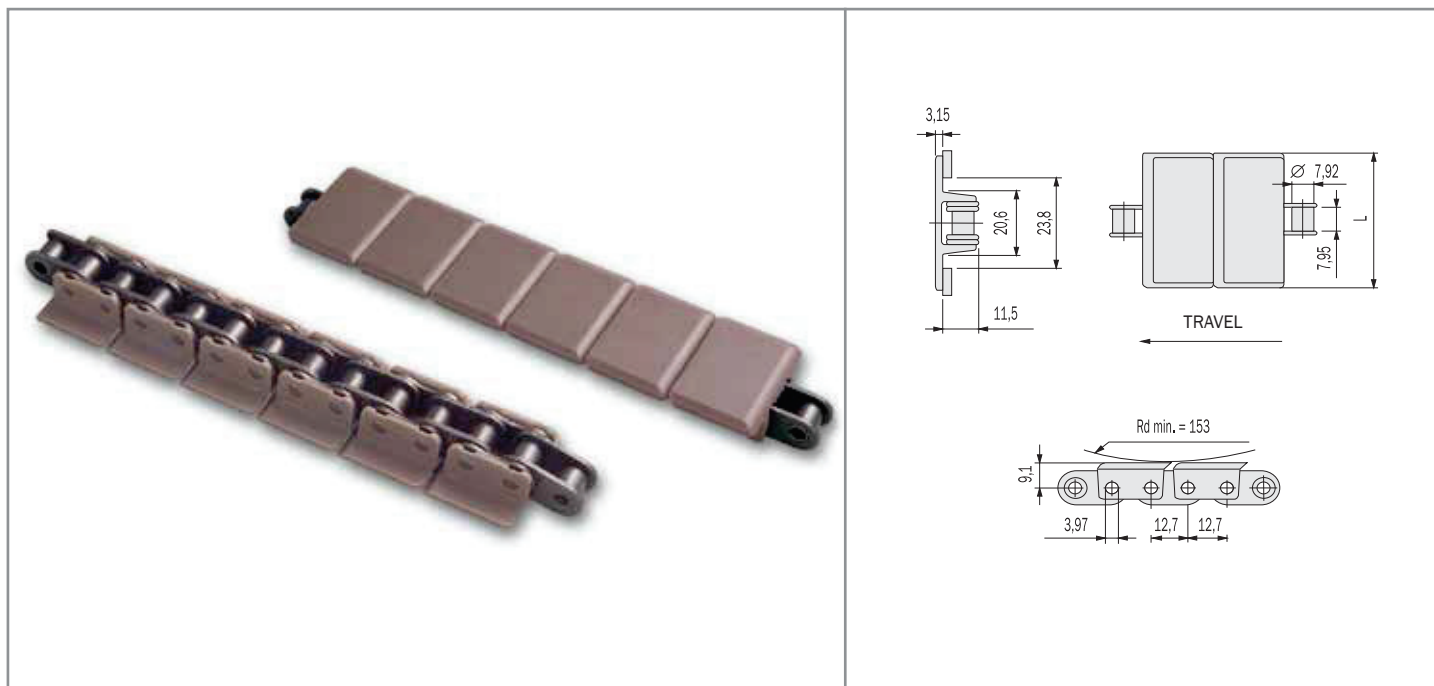

LFA 843 - LOW FRICTION ACETAL RESIN

- Plates in self-lubricating low friction acetal resin, light brown-coloured.
- Base roller chain, 12.7 mm - 1/2" pitch. - ANSI 43



p.214



p.232

PRODUCT CODE	INTERNAL CODE	CHARACTERISTICS			
		Base roller chain	Width L (mm)	Working load Max N (25 °C)	Weight kg/m
LFA 843 K138	843.AC.138	steel	34.9	3500	0.83
LFA 843 K144	843.AC.144	steel	36.5	3500	0.84
LFA 843 K200	843.AC.010	steel	50.8	3500	0.89
LFA 843 K250	843.AC.020	steel	63.5	3500	0.92
LFA 843 K275*	843.AC.200	steel	69.9	3500	0.94
LFA 843 K325	843.AC.040	steel	82.5	3500	1.03
LFA 843 SS K138	843.AS.138	stainless steel	34.9	2700	0.83
LFA 843 SS K144	843.AS.144	stainless steel	36.5	2700	0.84
LFA 843 SS K200	843.AS.010	stainless steel	50.8	2700	0.89
LFA 843 SS K250	843.AS.020	stainless steel	63.5	2700	0.92
LFA 843 SS K275*	843.AS.200	stainless steel	69.9	2700	0.94
LFA 843 SS K325	843.AS.040	stainless steel	82.5	2700	1.03

- * Size produced only upon request. Delivery conditions and terms to be agreed.
- Standard shipping lengths = 240 pitches = 10 feet = 3,048 metres.

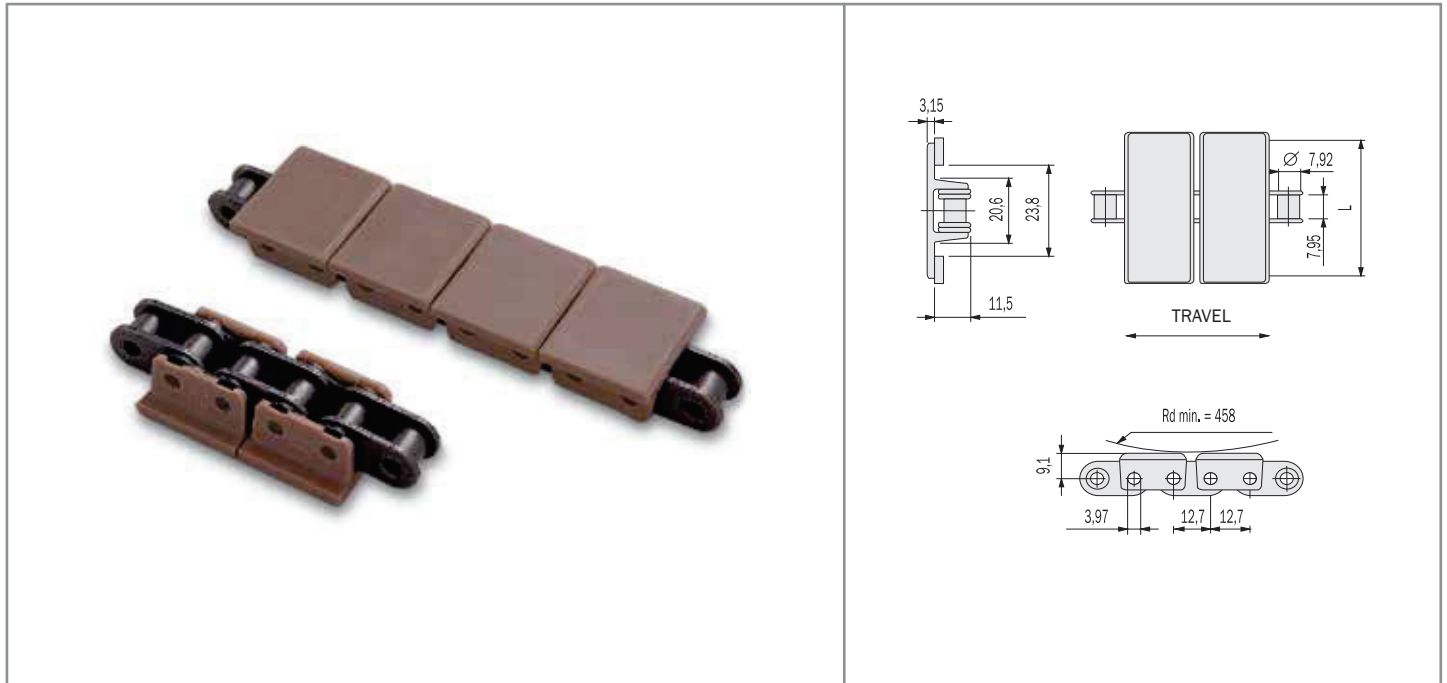

straight running chains

WITH THERMOPLASTIC TOP PLATES - 845 SERIES



LFA 845 - LOW FRICTION ACETAL RESIN

- Plates in self-lubricating low friction acetal resin, light brown-coloured.
- Base roller chain, 12.7 mm - 1/2" pitch. - ANSI 43

 
p.214 p.232

PRODUCT CODE	INTERNAL CODE	CHARACTERISTICS			
		Base roller chain	Width L (mm)	Working load Max N (25 °C)	Weight kg/m
LFA 845 K118*	845.AC.118	steel	28.6	3500	0.85
LFA 845 K138	845.AC.138	steel	34.9	3500	0.89
LFA 845 K200*	845.AC.010	steel	50.8	3500	0.99
LFA 845 SS K118*	845.AS.118	stainless steel	28.6	2700	0.85
LFA 845 SS K138*	845.AS.138	stainless steel	34.9	2700	0.89
LFA 845 SS K200*	845.AS.010	stainless steel	50.8	2700	0.99

* Size produced only upon request. Delivery conditions and terms to be agreed.
- Standard shipping lengths = 240 pitches = 10 feet = 3,048 metres.

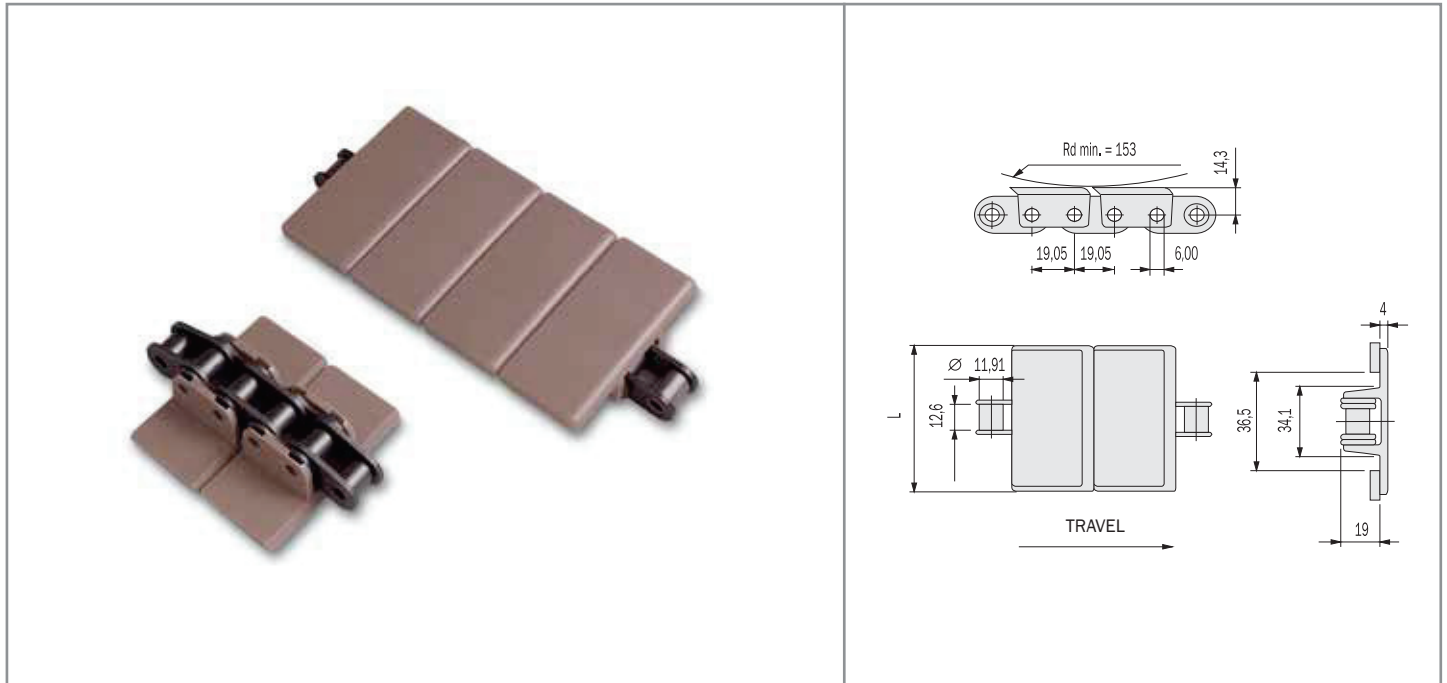

straight running chains

WITH THERMOPLASTIC TOP PLATES - 863 SERIES



LFA 863 - LOW FRICTION ACETAL RESIN

- Plates in self-lubricating low friction acetal resin, light brown-coloured.
- Base roller chain, 19.05 mm - 3/4" pitch. - ANSI 63

 
p.214 p.232

PRODUCT CODE	INTERNAL CODE	CHARACTERISTICS			
		Base roller chain	Width L (mm)	Working load Max N (25 °C)	Weight kg/m
LFA 863 K175*	863.AC.300	steel	44.5	5500	1.8
LFA 863 K225	863.AC.015	steel	57.1	5500	1.9
LFA 863 K250*	863.AC.020	steel	63.5	5500	2.0
LFA 863 K325	863.AC.040	steel	82.5	5500	2.1
LFA 863 K450	863.AC.080	steel	114.3	5500	2.3
LFA 863 K600	863.AC.100	steel	152.4	5500	2.5
LFA 863 K750	863.AC.110	steel	190.5	5500	2.7
LFA 863 SS K175*	863.AS.300	stainless steel	44.5	4500	1.8
LFA 863 SS K225	863.AS.015	stainless steel	57.1	4500	1.9
LFA 863 SS K250*	863.AS.020	stainless steel	63.5	4500	2.0
LFA 863 SS K325	863.AS.040	stainless steel	82.5	4500	2.1
LFA 863 SS K450	863.AS.080	stainless steel	114.3	4500	2.3
LFA 863 SS K600	863.AS.100	stainless steel	152.4	4500	2.5
LFA 863 SS K750	863.AS.110	stainless steel	190.5	4500	2.7

* Size produced only upon request. Delivery conditions and terms to be agreed.
 - Standard shipping lengths = 160 pitches = 10 feet = 3,048 metres.

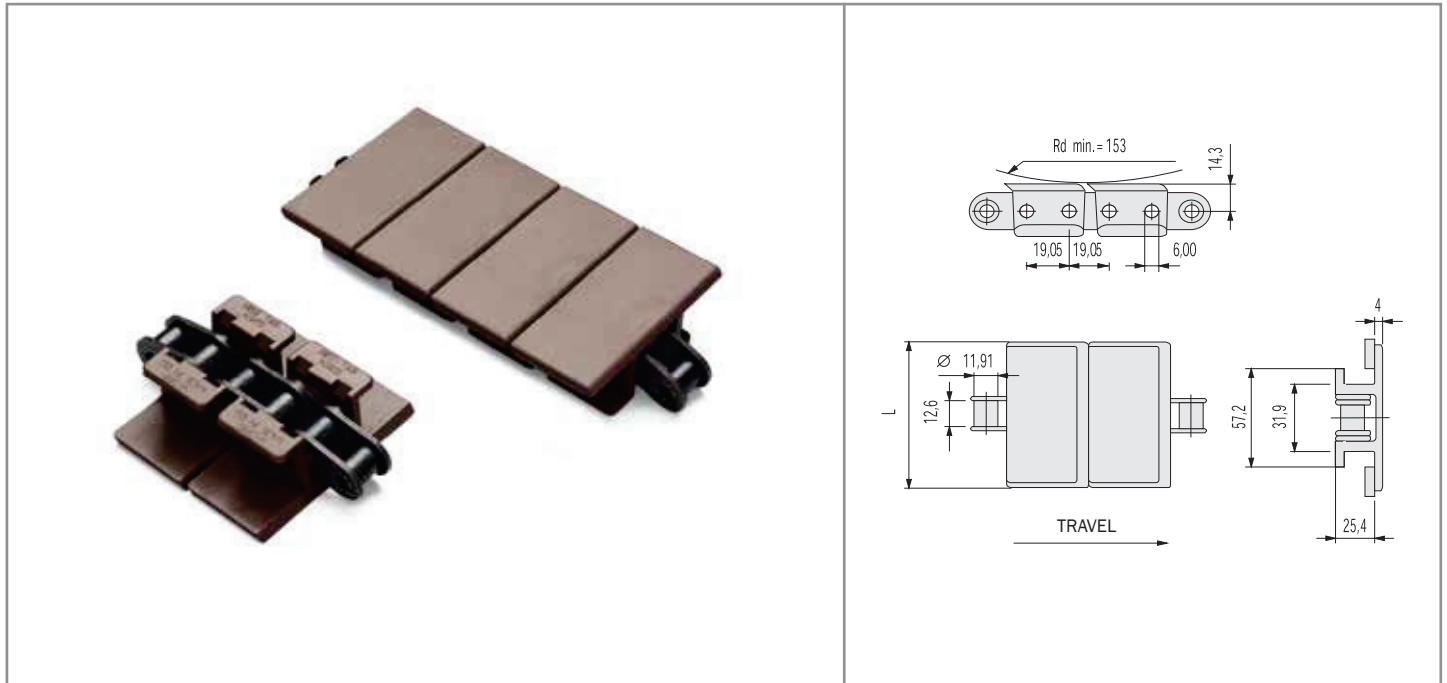

straight running chains

WITH THERMOPLASTIC TOP PLATES - 863 TAB SERIES



LFA 863 TAB - LOW FRICTION ACETAL RESIN

- Plates in self-lubricating low friction acetal resin, light brown-coloured.
- Base roller chain, 19.05 mm - 3/4" pitch. - ANSI 63

 
p.214 p.232

PRODUCT CODE	INTERNAL CODE	CHARACTERISTICS			
		Base roller chain	Width L (mm)	Working load Max N (25 °C)	Weight kg/m
LFA 863 TAB K250	863.AC.021	steel	63.5	5500	2.10
LFA 863 TAB K325	863.AC.041	steel	82.5	5500	2.20
LFA 863 TAB K450	863.AC.081	steel	114.3	5500	2.40
LFA 863 TAB K600	863.AC.101	steel	152.4	5500	2.60
LFA 863 TAB K1000	863.AC.121	steel	254.0	5500	3.10
LFA 863 TAB SS K250	863.AS.021	stainless steel	63.5	4500	2.10
LFA 863 TAB SS K325	863.AS.041	stainless steel	82.5	4500	2.20
LFA 863 TAB SS K450	863.AS.081	stainless steel	114.3	4500	2.40
LFA 863 TAB SS K600	863.AS.101	stainless steel	152.4	4500	2.60
LFA 863 TAB SS K1000	863.AS.121	stainless steel	254.0	4500	3.10

- Standard shipping lengths = 160 pitches = 10 feet = 3,048 metres.

straight running chains

WITH THERMOPLASTIC TOP PLATES - 963 SERIES

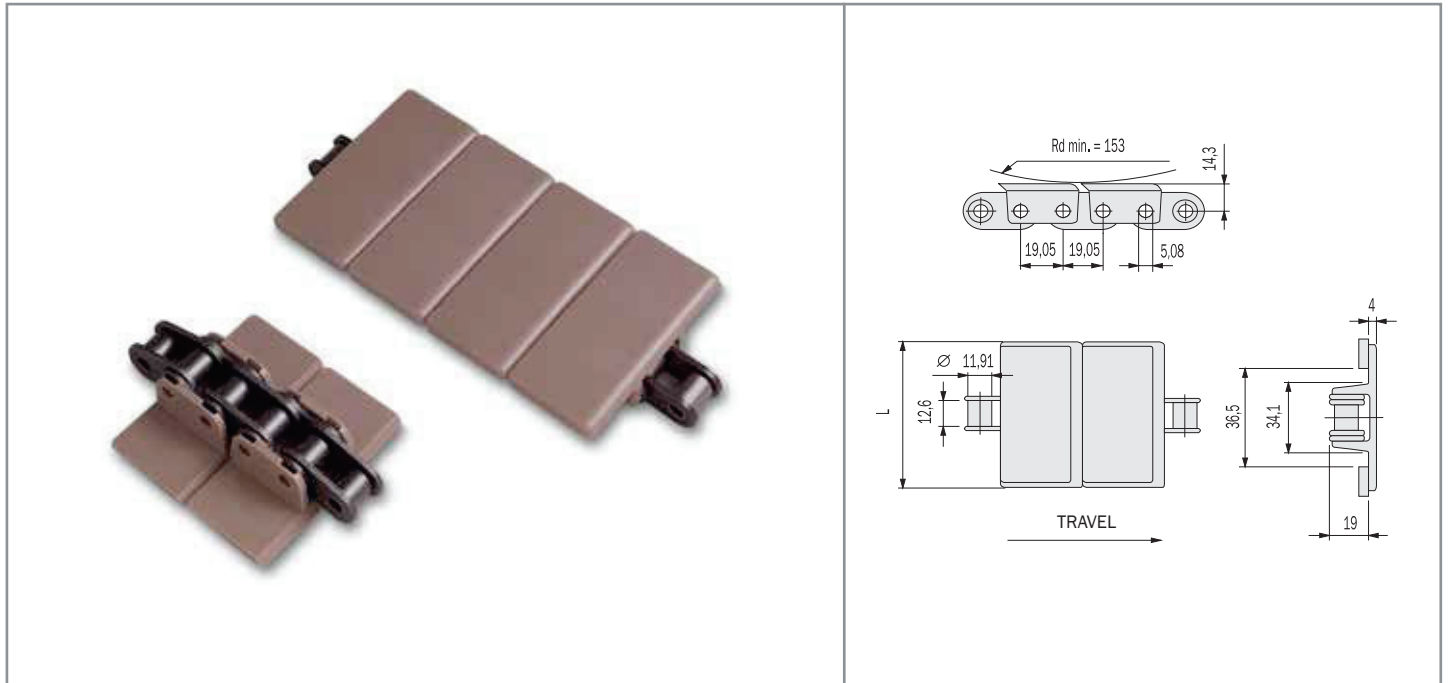

LFA 963 - LOW FRICTION ACETAL RESIN

- Plates in self-lubricating low friction acetal resin, light brown-coloured.
- Base roller chain, 19.05 mm - 3/4" pitch. - ANSI 63 SB

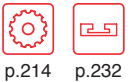

PRODUCT CODE	INTERNAL CODE	CHARACTERISTICS			
		Base roller chain	Width L (mm)	Working load Max N (25 °C)	Weight kg/m
LFA 963 K325	963.AC.040	steel	82.5	4500	2.10
LFA 963 K450	963.AC.080	steel	114.3	4500	2.23
LFA 963 K600	963.AC.100	steel	152.4	4500	2.53
LFA 963 K750	963.AC.110	steel	190.5	4500	2.68
LFA 963 SS K325	963.AS.040	stainless steel	82.5	3500	2.10
LFA 963 SS K450	963.AS.080	stainless steel	114.3	3500	2.23
LFA 963 SS K600	963.AS.100	stainless steel	152.4	3500	2.53
LFA 963 SS K750	963.AS.110	stainless steel	190.5	3500	2.68

- Standard shipping lengths = 160 pitches = 10 feet = 3,048 metres.

sideflexing chains

WITH THERMOPLASTIC TOP PLATES - 1843 TAB SERIES

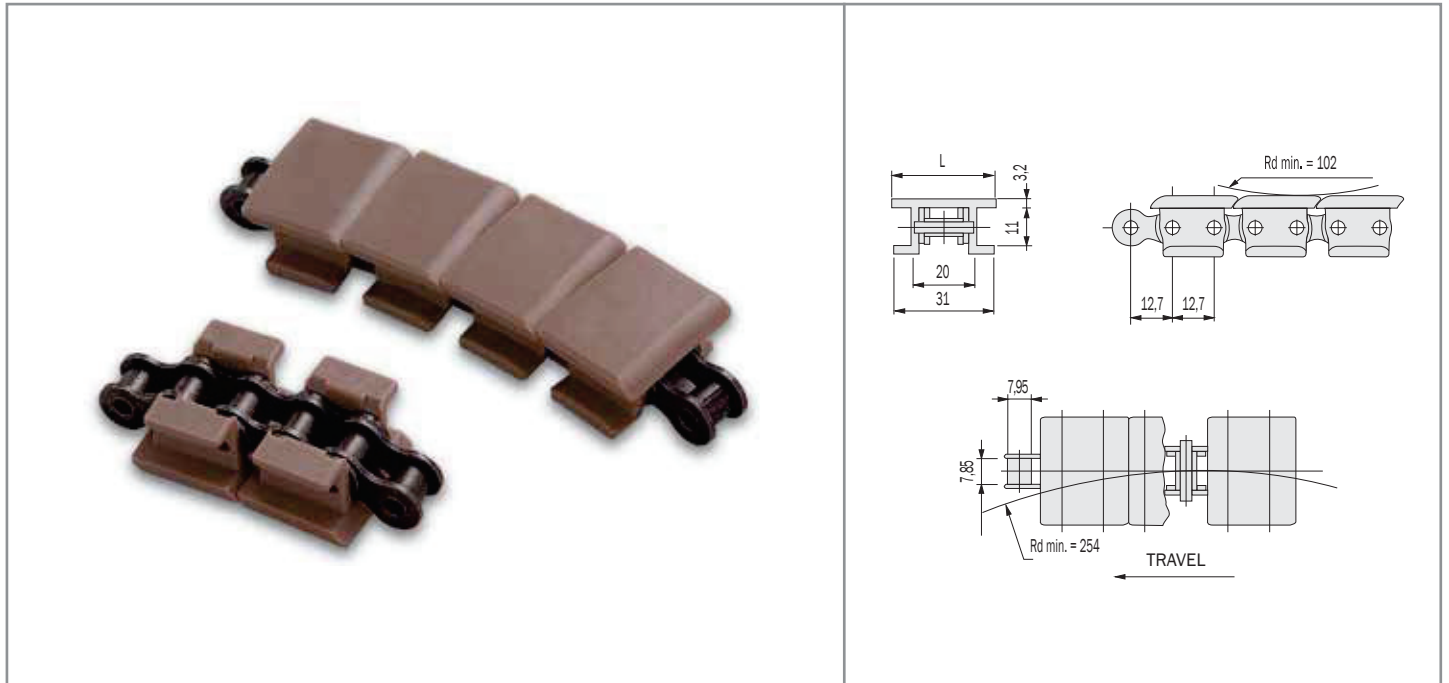

LFA 1843 TAB - LOW FRICTION ACETAL RESIN

- Plates in self-lubricating low friction acetal resin, light brown-coloured.
- Base roller chain, 12.7 mm - 1/2" pitch. - ANSI 43 SB



p.214

p.226

p.228

PRODUCT CODE	INTERNAL CODE	CHARACTERISTICS			
		Base roller chain	Width L (mm)	Working load Max N (25 °C)	Weight kg/m
LFA 1843 TAB K125	1843.AC.280	steel	31.8	2600	0.74
LFA 1843 TAB K200	1843.AC.010	steel	50.8	2600	0.89
LFA 1843 TAB K325	1843.AC.041	steel	82.5	2600	1.03
LFA 1843 TAB SS K125	1843.AS.280	stainless steel	31.8	2000	0.74
LFA 1843 TAB SS K200	1843.AS.010	stainless steel	50.8	2000	0.89
LFA 1843 TAB SS K325	1843.AS.041	stainless steel	82.5	2000	1.03

- Standard shipping lengths = 240 pitches = 10 feet = 3,048 metres.

sideflexing chains

WITH THERMOPLASTIC TOP PLATES - 1863 TAB SERIES

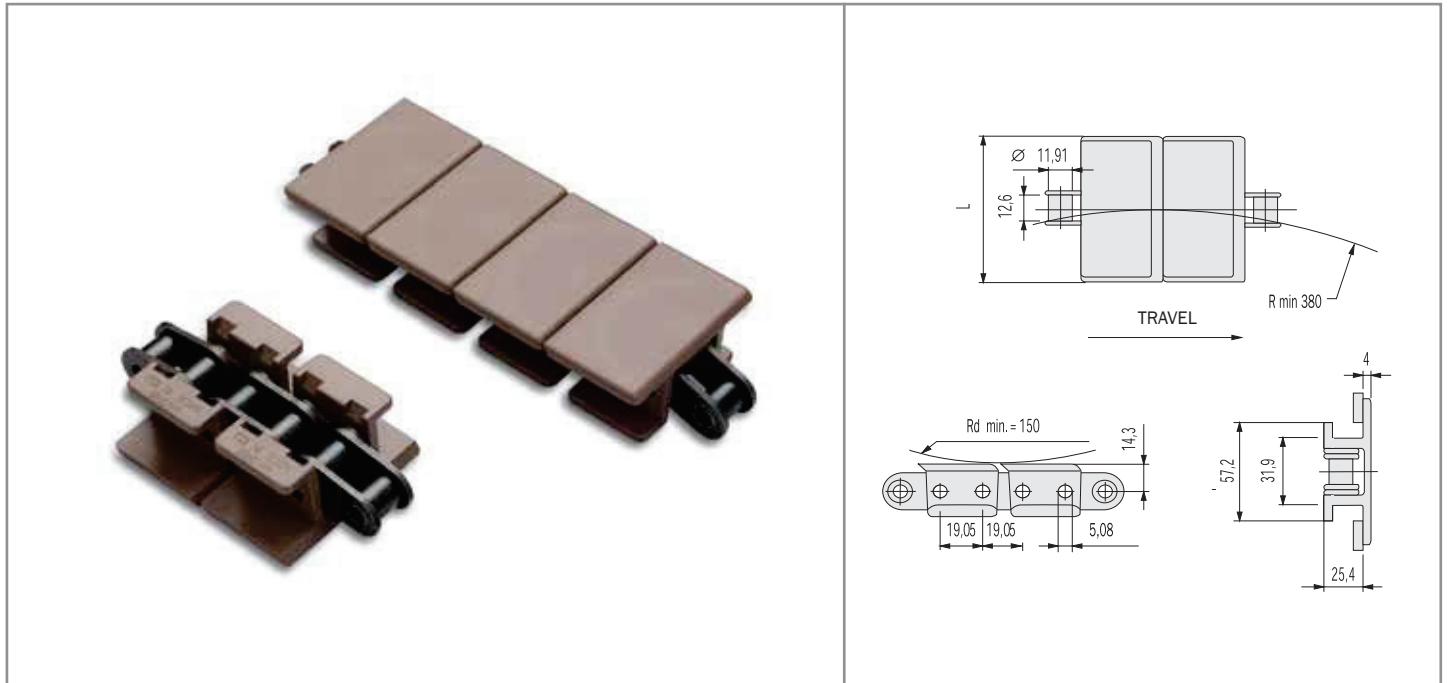

LFA 1863 TAB - LOW FRICTION ACETAL RESIN

- Plates in self-lubricating low friction acetal resin, light brown-coloured.
- Base roller chain, 19.05 mm - 3/4" pitch. - ANSI 63 SB



PRODUCT CODE	INTERNAL CODE	CHARACTERISTICS			
		Base roller chain	Width L (mm)	Working load Max N (25 °C)	Weight kg/m
LFA 1863 TAB K225	1863.AC.016	steel	57.1	5500	2.00
LFA 1863 TAB SS K225	1863.AS.016	stainless steel	57.1	4500	2.00

- Standard shipping lengths = 160 pitches = 10 feet = 3,048 metres.

sideflexing chains

WITH THERMOPLASTIC TOP PLATES - 1873 TAB SERIES

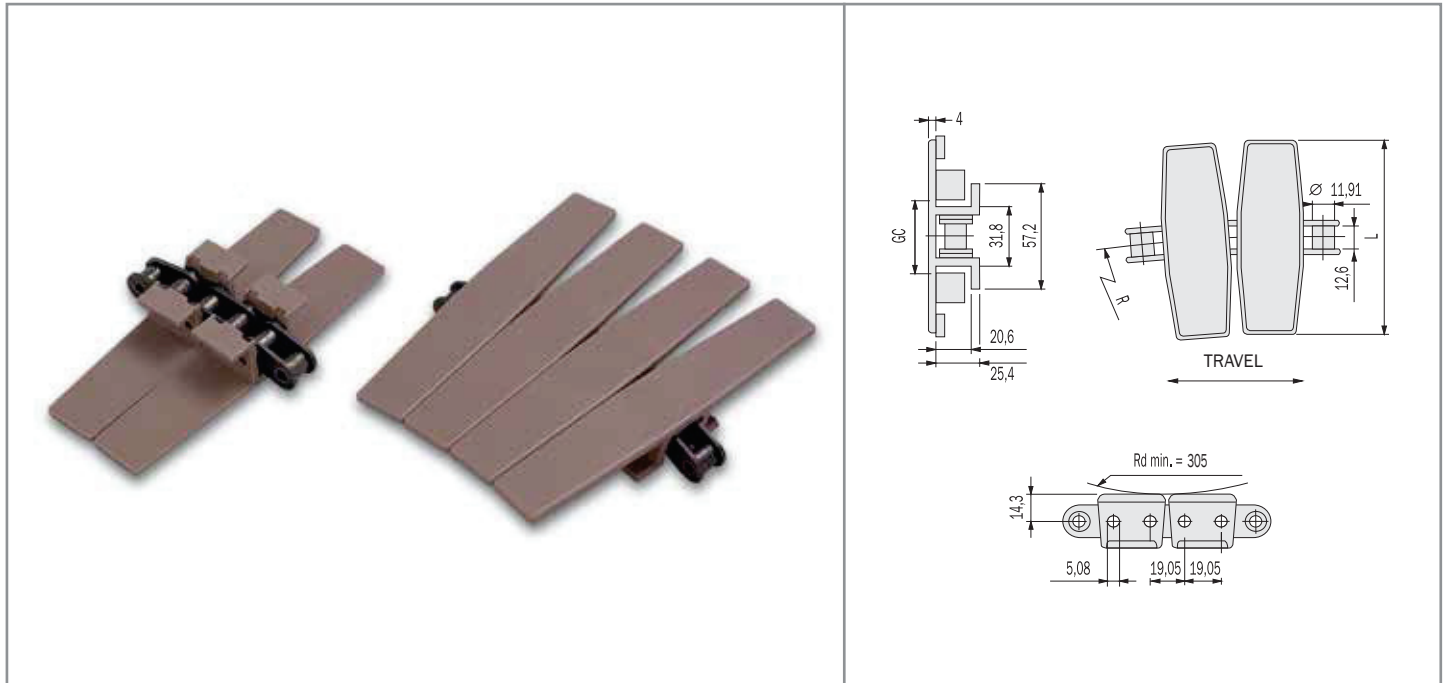

LFA 1873 TAB - LOW FRICTION ACETAL RESIN

- Plates in self-lubricating low friction acetal resin, light brown-coloured.
- Base roller chain, 19.05 mm - 3/4" pitch. - ANSI 63 SB



PRODUCT CODE		INTERNAL CODE		CHARACTERISTICS				
		Base roller chain	Width L (mm)	Radius R (mm)	GC st. (mm)	GC sid. (mm)	Working load Max N (25 °C)	Weight kg/m
LFA 1873 TAB K325	1873.AC.041	steel	82.5	356	33.3	34.6	5500	2.10
LFA 1873 TAB K450	1873.AC.081	steel	114.3	356	33.3	34.6	5500	2.30
LFA 1873 TAB K600	1873.AC.101	steel	152.4	457	33.3	34.6	5500	2.40
LFA 1873 TAB K750	1873.AC.111	steel	190.5	457	33.3	34.6	5500	2.60
LFA 1873 TAB K1000	1873.AC.121	steel	254.0	457	33.3	34.6	5500	2.80
LFA 1873 TAB K1200	1873.AC.131	steel	304.8	610	33.3	34.6	5500	3.00
LFA 1873 TAB SS K325	1873.AS.041	stainless steel	82.5	356	33.3	34.6	4500	2.10
LFA 1873 TAB SS K450	1873.AS.081	stainless steel	114.3	356	33.3	34.6	4500	2.30
LFA 1873 TAB SS K600	1873.AS.101	stainless steel	152.4	457	33.3	34.6	4500	2.40
LFA 1873 TAB SS K750	1873.AS.111	stainless steel	190.5	457	33.3	34.6	4500	2.60
LFA 1873 TAB SS K1000	1873.AS.121	stainless steel	254.0	457	33.3	34.6	4500	2.80
LFA 1873 TAB SS K1200	1873.AS.131	stainless steel	304.8	610	33.3	34.6	4500	3.00

- Standard shipping lengths = 160 pitches = 10 feet = 3,048 metres.

thermoplastic straight running chains

WITH RUBBER INSERTS - SINGLE HINGE - HFL 820 SERIES

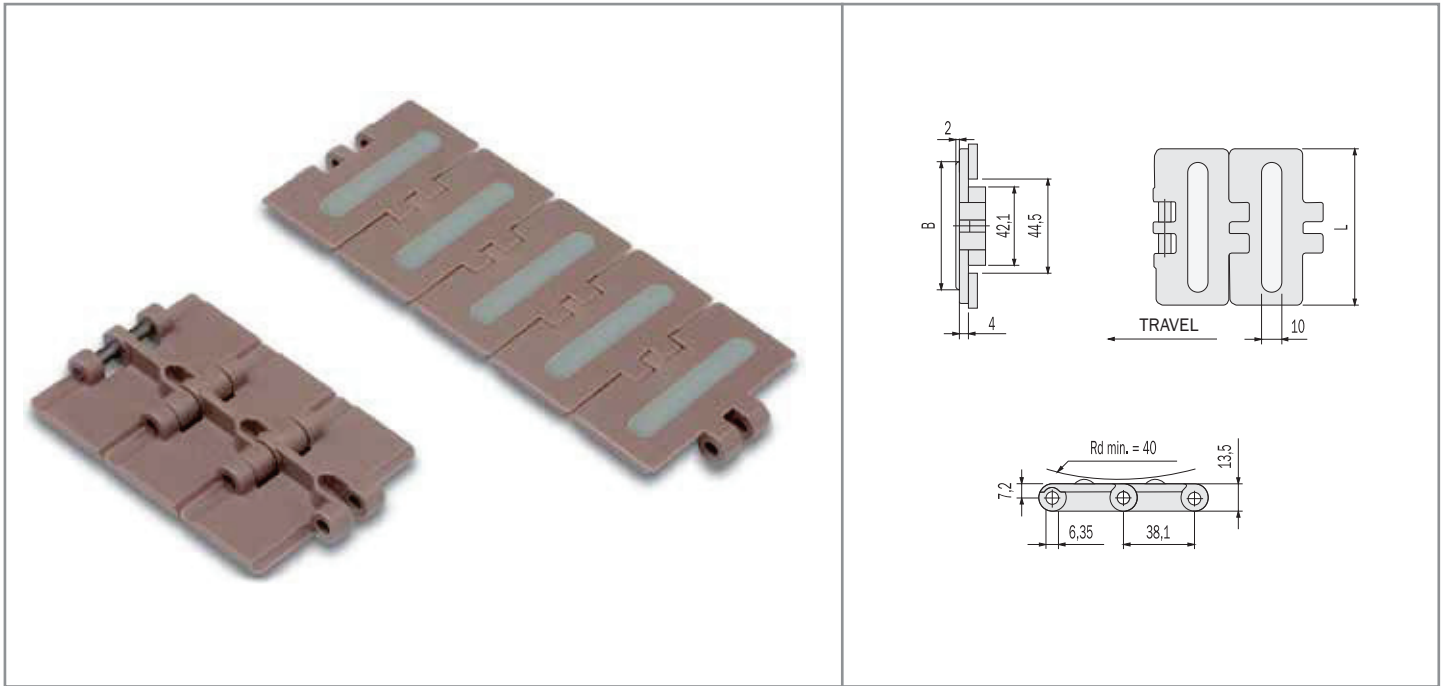

HFL 820 - HIGH FRICTION LINK

- Plates in self-lubricating acetal resin, light brown-coloured, with a rubber insert.
- Pins in special chrome-nickel stainless steel, work hardened for high resistance.



p.169
p.210



p.230
p.232

PRODUCT CODE	INTERNAL CODE	CHARACTERISTICS			
		Width L (mm)	B (mm)	Working Load Max N (21°C)	Weight kg/m
HFL 820 K325*	G.6.10.040	82.5	65.0	1230	0.83
HFL 820 K350*	G.6.10.060	88.9	88.9	1230	0.87
HFL 820 K400*	G.6.10.070	101.6	101.6	1230	0.95
HFL 820 K450*	G.6.10.080	114.3	114.3	1230	1.03
HFL 820 K600*	G.6.10.100	152.4	135.0	1230	1.25

- Inserts: rubber 60 shore A (grey).
- * Size produced only upon request. Delivery conditions and terms to be agreed.
- Standard shipping lengths = 80 pitches = 10 feet = 3,048 metres.
- Special configurations of distance between inserts are available upon request. Delivery conditions and terms to be agreed.
- These chains can be supplied either with pins in austenitic stainless steel, work hardened, highly wear resistant, or with pins in thermoplastic resin.

thermoplastic straight running chains

WITH RUBBER INSERTS - DOUBLE HINGE - HFL 821 SERIES

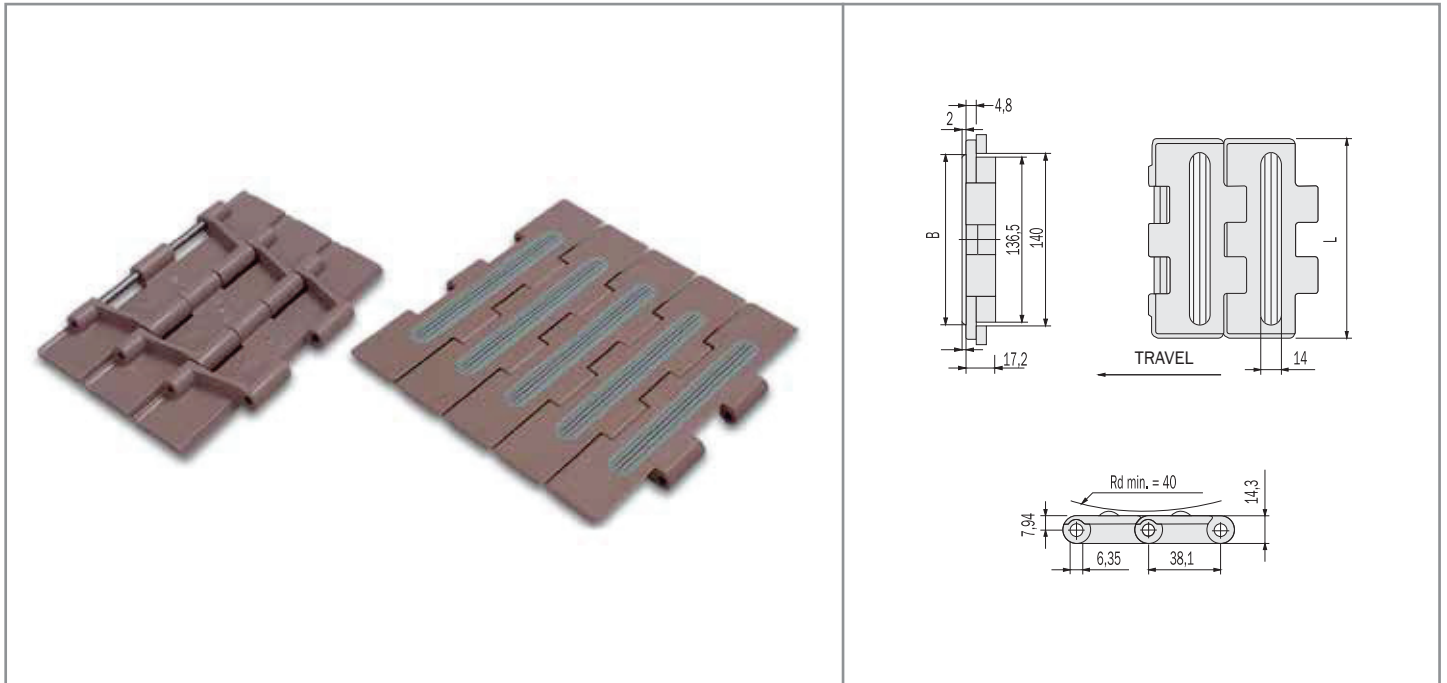

HFL 821 - HIGH FRICTION LINK

- Plates in self-lubricating acetal resin, light brown-coloured, with a rubber insert.
- Pins in special chrome-nickel stainless steel, work hardened for high resistance.

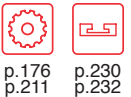

PRODUCT CODE	INTERNAL CODE	CHARACTERISTICS			
		Width L (mm)	B (mm)	Working Load Max N (21°C)	Weight kg/m
HFL 821 K750*	G.6.14.110	190.5	132.0	2680	2.50
HFL 821 K1000*	G.6.14.120	254.0	195.0	2680	2.95
HFL 821 K1200*	G.6.14.130	304.8	245.0	2680	3.25

- Inserts: rubber 60 shore A (grey).
- * Size produced only upon request. Delivery conditions and terms to be agreed.
- Standard shipping lengths = 80 pitches = 10 feet = 3,048 metres.
- Special configurations of distance between inserts are available upon request. Delivery conditions and terms to be agreed.
- These chains can be supplied with pins in austenitic stainless steel, work hardened, highly wear resistant.

thermoplastic sideflexing chains

WITH RUBBER INSERTS - HFL 880 TAB SERIES

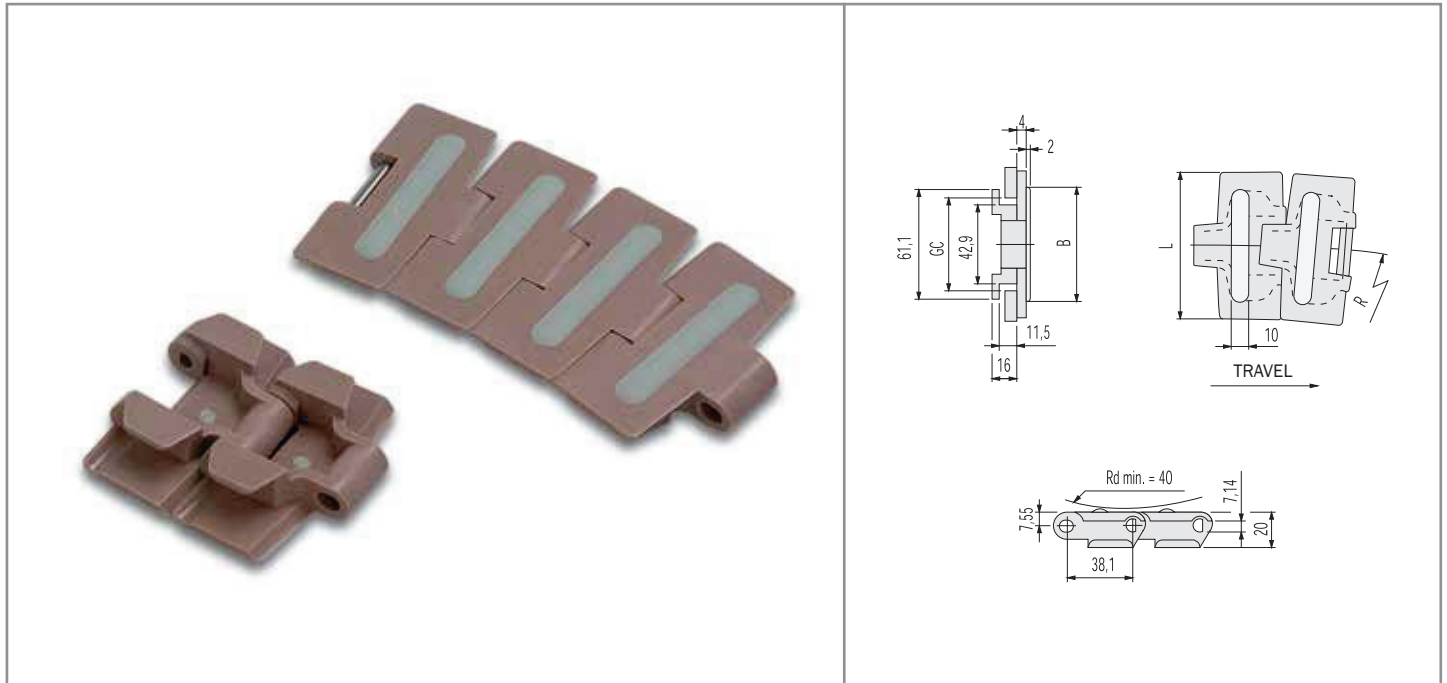

HFL 880 TAB - HIGH FRICTION LINK

- Plates in self-lubricating acetal resin, light brown coloured, with a rubber insert.
- Pins in special chrome-nickel stainless steel, work hardened for high resistance.



p.182
p.212



p.218



p.228
p.232

PRODUCT CODE		INTERNAL CODE		CHARACTERISTICS				
		Width L (mm)	B (mm)	R (mm)	GC st. (mm)	GC sid. (mm)	Work. Load Max N (21°C)	Weight kg/m
HFL 880 TAB K325*	G.6.12.041	82.5	65.0	400	46	44.2	2100	0.94
HFL 880 TAB K450*	G.6.12.081	114.3	95.0	400	46	44.2	2100	1.08

- Inserts: rubber 60 shore A (grey).
- * Size produced only upon request. Delivery conditions and terms to be agreed.
- Standard shipping lengths = 80 pitches = 10 feet = 3,048 metres.
- Special configurations of distance between inserts are available upon request. Delivery conditions and terms to be agreed.
- These chains can be supplied either with pins in austenitic stainless steel, work hardened, highly wear resistant, or with pins in thermoplastic resin.

thermoplastic sideflexing chains

WITH RUBBER INSERTS - HFL 880 BO SERIES

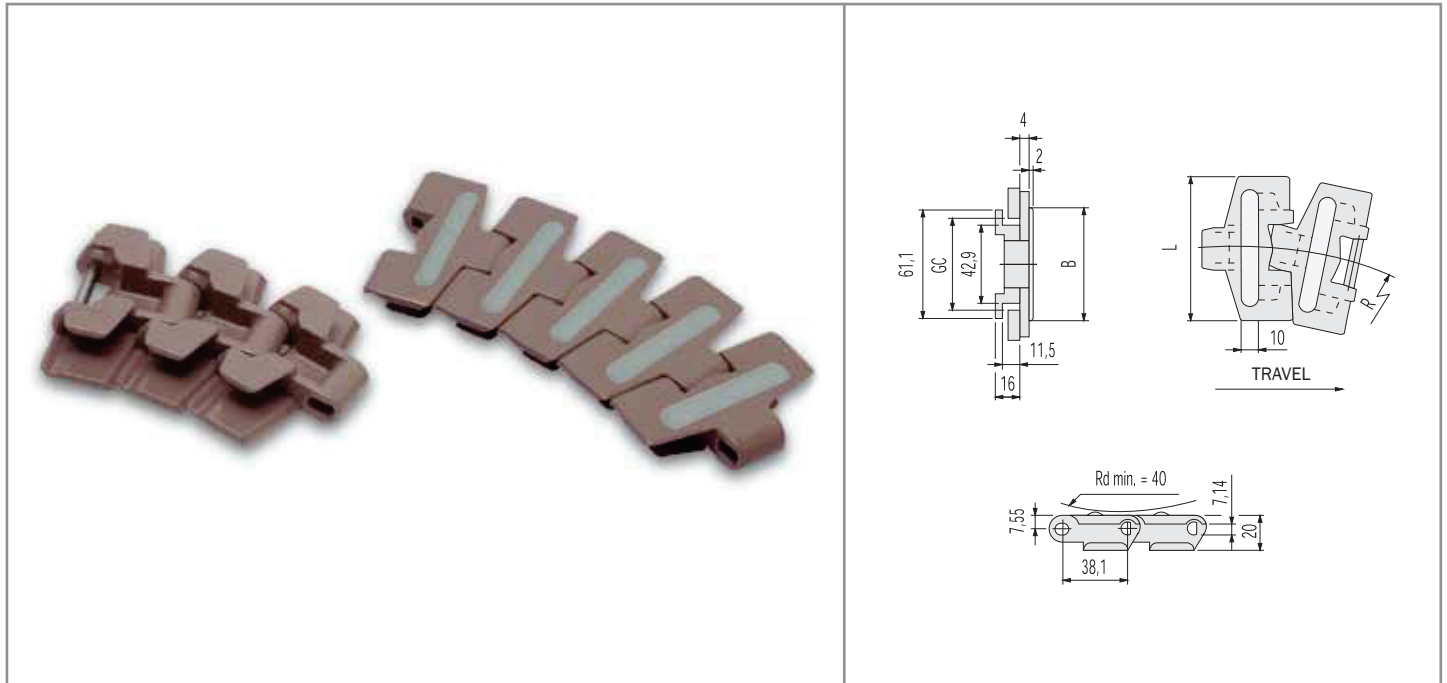

HFL 880 BO - HIGH FRICTION LINK

- Plates in self-lubricating acetal resin, light brown-coloured, with a rubber insert.
- Pins in special chrome-nickel stainless steel, work hardened for high resistance.



p.182
p.208
p.212

p.218

p.228
p.232

PRODUCT CODE	INTERNAL CODE	CHARACTERISTICS						
		Width L (mm)	B (mm)	R (mm)	GC st. (mm)	GC sid. (mm)	Work. Load Max N (21°C)	Weight kg/m
HFL 880 BO K325*	G.6.19.040	82.5	65.0	190	46	44.2	1680	0.96

- Inserts: rubber 60 shore A (grey).
- * Size produced only upon request. Delivery conditions and terms to be agreed.
- Standard shipping lengths = 80 pitches = 10 feet = 3,048 metres.
- Special configurations of distance between inserts are available upon request.
- Delivery conditions and terms to be agreed.
- These chains can be supplied either with pins in austenitic stainless steel, work hardened, highly wear resistant, or with pins in thermoplastic resin.

thermoplastic sideflexing chains

WITH RUBBER INSERTS - HFL 878 BO SERIES

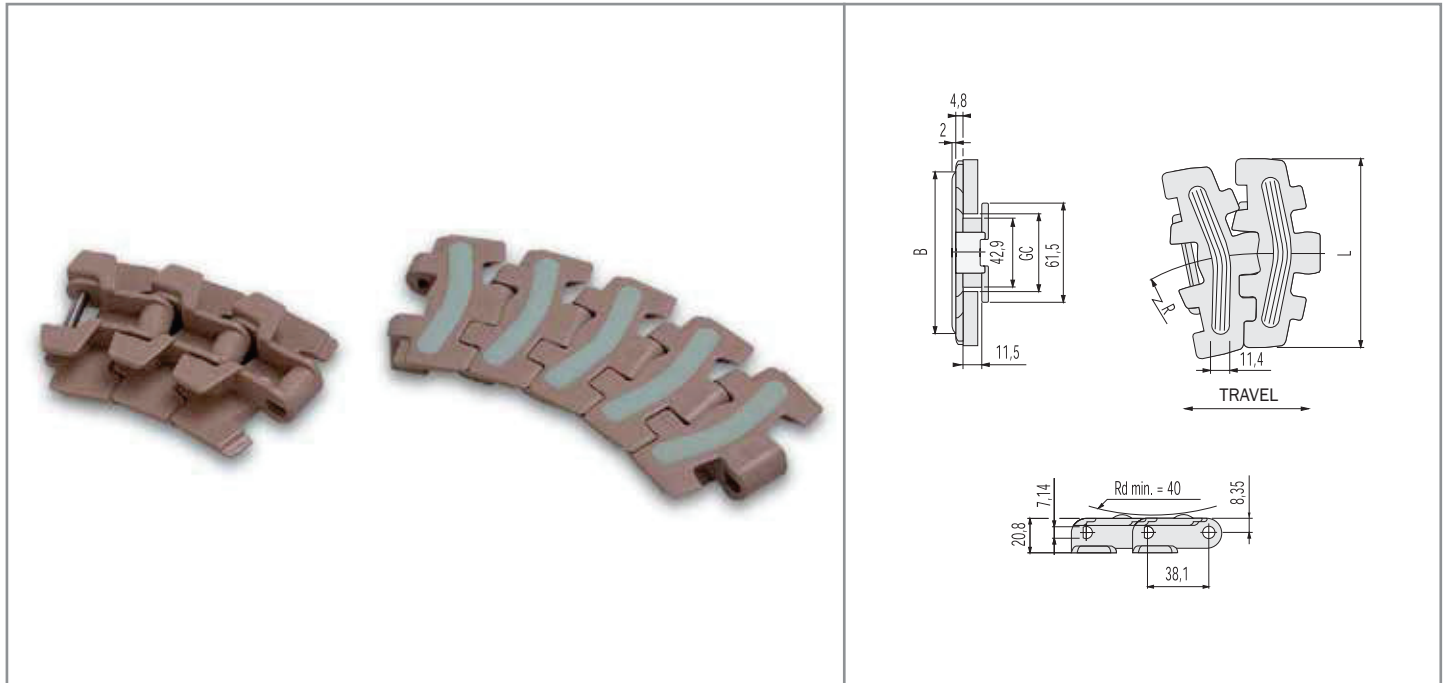

HFL 878 BO - HIGH FRICTION LINK

- Plates in self-lubricating acetal resin, light brown-coloured, with a rubber insert.
- Pins in special chrome-nickel stainless steel, work hardened for high resistance.



p.182
p.208
p.212

p.218

p.228
p.232

PRODUCT CODE		INTERNAL CODE		CHARACTERISTICS				
		Width L (mm)	B (mm)	R (mm)	GC st. (mm)	GC sid. (mm)	Work. Load Max N (21°C)	Weight kg/m
HFL 878 BO K325*	G.6.17.041	82.5	71.0	190	46	44.2	2100	1.08
HFL 878 BO K450*	G.6.17.081	114.3	102.0	190	46	44.2	2100	1.20

- Inserts: rubber 60 shore A (grey).

* Size produced only upon request. Delivery conditions and terms to be agreed.

- Standard shipping lengths = 80 pitches = 10 feet = 3,048 metres.

- Special configurations of distance between inserts are available upon request.

Delivery conditions and terms to be agreed.

- These chains can be supplied either with pins in austenitic stainless steel, work hardened, highly wear resistant, or with pins in thermoplastic resin.

thermoplastic sideflexing chains

WITH RUBBER INSERTS - HFL 882 TAB SERIES

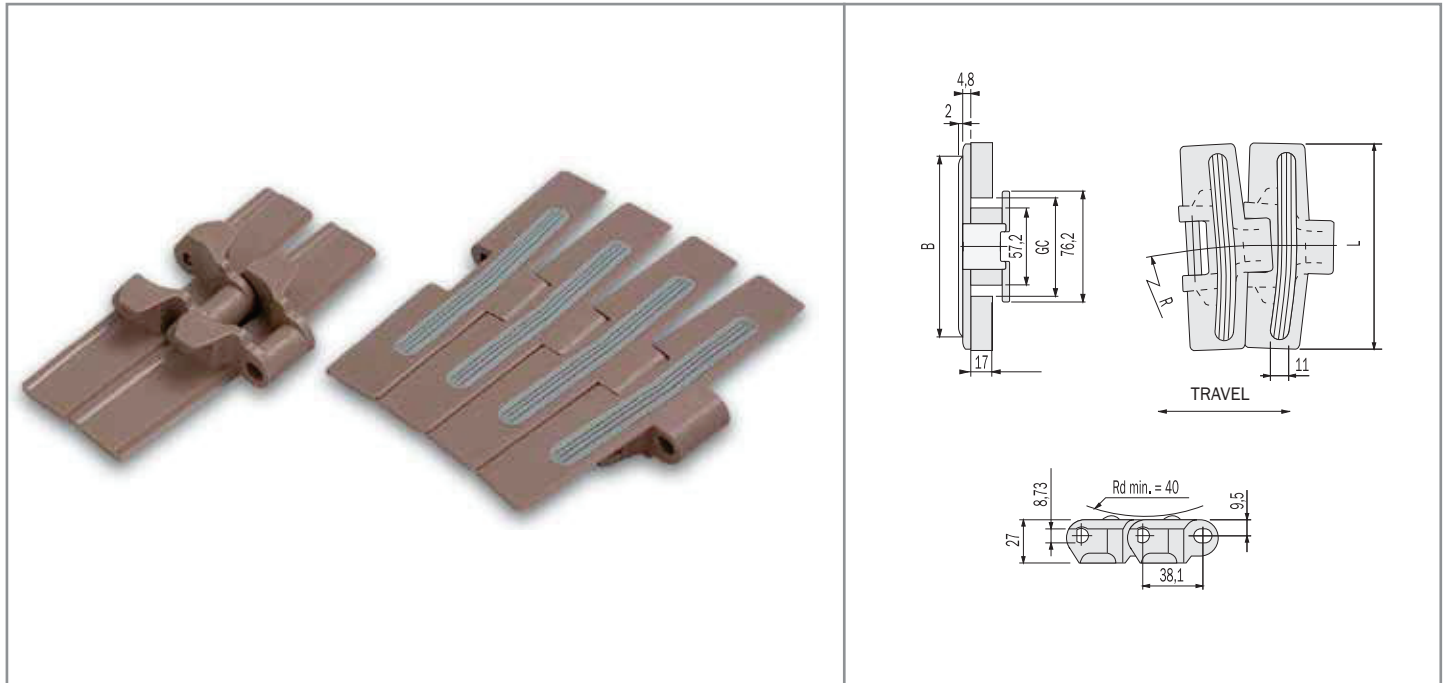

HFL 882 TAB - HIGH FRICTION LINK

- Plates in self-lubricating acetal resin, light brown-coloured, with a rubber insert.
- Pins in special chrome-nickel stainless steel, work hardened for high resistance.



p.182
p.212



p.222



p.228
p.232

PRODUCT CODE		INTERNAL CODE		CHARACTERISTICS				
		Width L (mm)	B (mm)	R (mm)	GC st. (mm)	GC sid. (mm)	Work. Load Max N (21°C)	Weight kg/m
HFL 882 TAB K750*	G.6.15.111	190.5	132.0	610	60	58	3830	2.43
HFL 882 TAB K1000*	G.6.15.121	254.0	195.0	610	60	58	3830	2.87
HFL 882 TAB K1200*	G.6.15.131	304.8	246.0	610	60	58	3830	3.41

- Inserts: rubber 60 shore A (grey).
- * Size produced only upon request. Delivery conditions and terms to be agreed.
- Standard shipping lengths = 80 pitches = 10 feet = 3,048 metres.
- Special configurations of distance between inserts are available upon request. Delivery conditions and terms to be agreed.
- These chains can be supplied either with pins in austenitic stainless steel, work hardened, highly wear resistant, or with pins in thermoplastic resin.

sideflexing chains with thermoplastic

TOP PLATES AND RUBBER INSERTS - HFL 1873 TAB SERIES

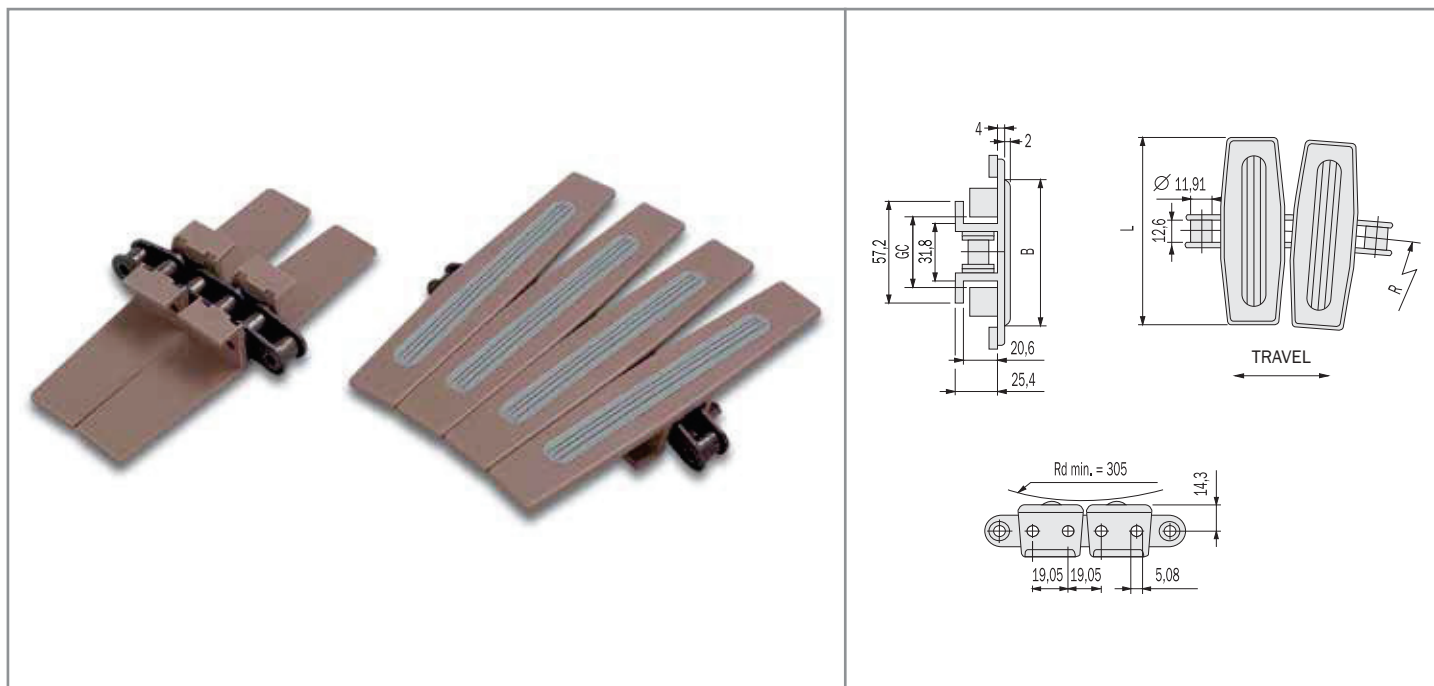

HFL 1873 TAB - HIGH FRICTION LINK

- Plates in self-lubricating acetal resin, light brown-coloured, with a rubber insert.
- Base roller chain, 19.05 mm - 3/4" pitch ANSI 63 SB.



p.214

p.225

p.228

PRODUCT CODE	INTERNAL CODE	CHARACTERISTICS							
		Base roller chain	Width L (mm)	B (mm)	R (mm)	GC st. (mm)	GC sid. (mm)	Working load Max N (25 °C)	Weight kg/m
HFL 1873 TAB K750	G.1873.AC.111	steel	190.5	132.0	457	33.3	34.6	5500	3.10
HFL 1873 TAB K1000	G.1873.AC.121	steel	254.0	195.0	457	33.3	34.6	5500	3.40
HFL 1873 TAB K1200	G.1873.AC.131	steel	304.8	245.0	457	33.3	34.6	5500	3.60
HFL 1873 TAB SS K750	G.1873.AS.111	stainless steel	190.5	132.0	457	33.3	34.6	4500	3.10
HFL 1873 TAB SS K1000	G.1873.AS.121	stainless steel	254.0	195.0	457	33.3	34.6	4500	3.40
HFL 1873 TAB SS K1200	G.1873.AS.131	stainless steel	304.8	245.0	457	33.3	34.6	4500	3.60

- Inserts: rubber 60 shore A (grey).
 - Standard shipping lengths = 160 pitches = 10 feet = 3,048 metres.
 - Special configurations of distance between inserts are available upon request.
- Delivery conditions and terms to be agreed.

sideflexing plastic gripper chains

1873 GS SERIES

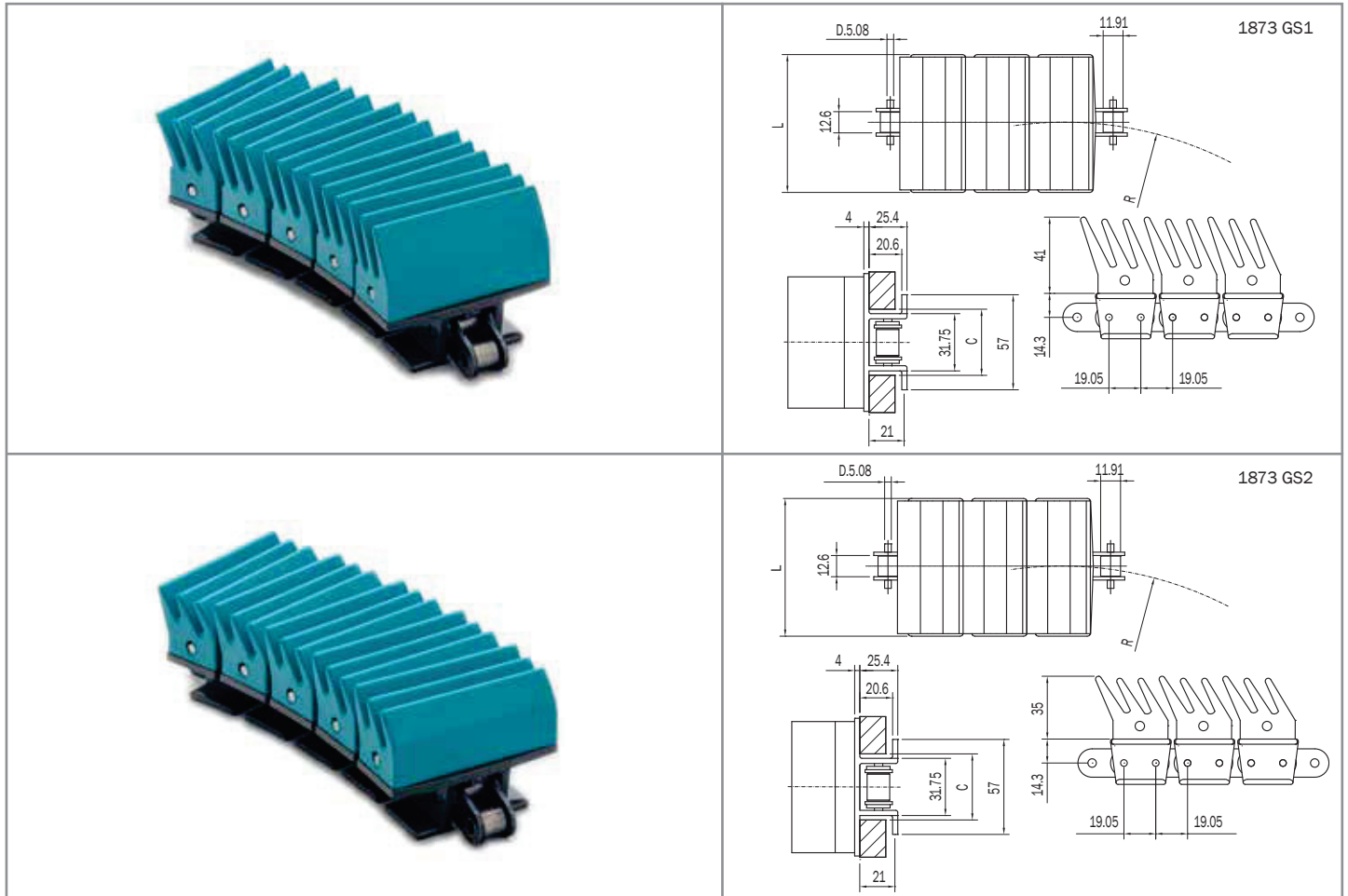

GS 1873 SERIES

Application: High speed conveyors, packaged products and conveying pet containers.
Benefits: High wear resistance, exceptional durability, extremely low noise performance, removable gripper.



p.214 p.225 p.228

- Plates in self-lubricating, very low friction acetal resin, dark grey-coloured.
- Gripper pads are made in NBR material
- Base roller chain, 19.05mm - 3/4" pitch ANSI 63 SB

PRODUCT CODE	INTERNAL CODE	CHARACTERISTICS					
		Base roller chain	Slat with (mm)	R (mm)	C (mm)	Working load Max N (25 °C)	Weight kg/m
SP 1873 GS1 K325	1873.GS1.041	steel	82.5	380	35	5500	4.70
SP 1873 GS1 K450	1873.GS1.081	steel	114.3	380	35	5500	7.10
SP 1873 SS GS1 K325	1873.SGS1.041	stainless steel	82.5	380	35	4500	4.70
SP 1873 SS GS1 K450	1873.SGS1.081	stainless steel	114.3	380	35	4500	7.10
SP 1873 GS2 K325	1873.GS2.041	steel	82.5	380	35	5500	4.10
SP 1873 GS2 K450	1873.GS2.081	steel	114.3	380	35	5500	6.40
SP 1873 SS GS2 K325	1873.SGS2.041	stainless steel	82.5	380	35	4500	4.10
SP 1873 SS GS2 K450	1873.SGS2.081	stainless steel	114.3	380	35	4500	6.40

- Standard shipping lengths = 160 pitches = 10 feet = 3,048 metres.

sideflexing gripper chains

1874 GV SERIES

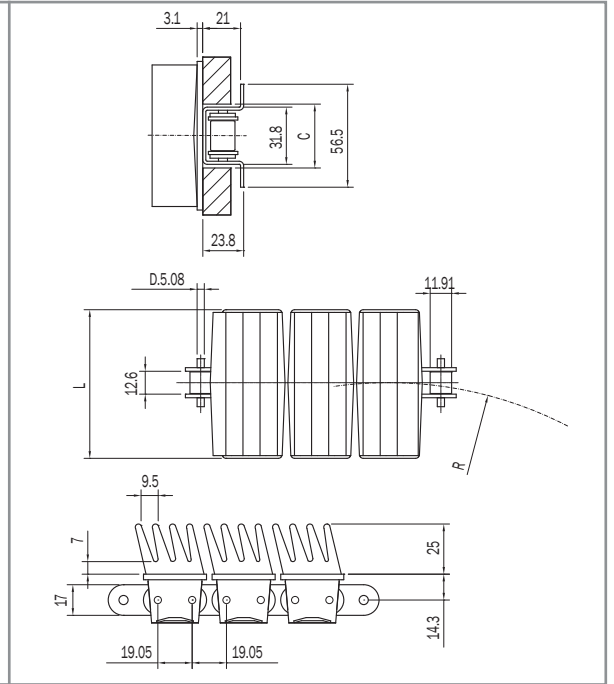

GV 1874 SERIES

Application: Conveying heavier containers, packaged products and conveying glass containers.
Benefits: High laceration and abrasion resistance, excellent resistance to fatigue and heat.



- Steel and stainless steel top plates
- Gripper pads are made in NBR or EPDM rubber
- Base roller chain, 19.05mm - 3/4" pitch ANSI 63 SB

PRODUCT CODE	INTERNAL CODE	CHARACTERISTICS					
		Rubber material	Slat with (mm)	R (mm)	C (mm)	Working load Max N (25 °C)	Weight kg/m
GV 1874 K325	1874.CSG.041	NRB	82.5	380	35	5500	5.80
GV 1874 SS K325	1874.SSG.041	NRB	82.5	380	35	4500	5.80
GVH 1874 SS K325	1874.SSGH.041	EPDM	82.5	380	35	4500	5.80

NOTE OF MATERIALS

1874 - steel base roller chain, steel top plate

1874 SS - stainless steel base roller chain, stainless steel top plate

- Standard shipping lengths = 160 pitches = 10 feet = 3,048 metres.

biplanar thermoplastic chains

1500 SERIES

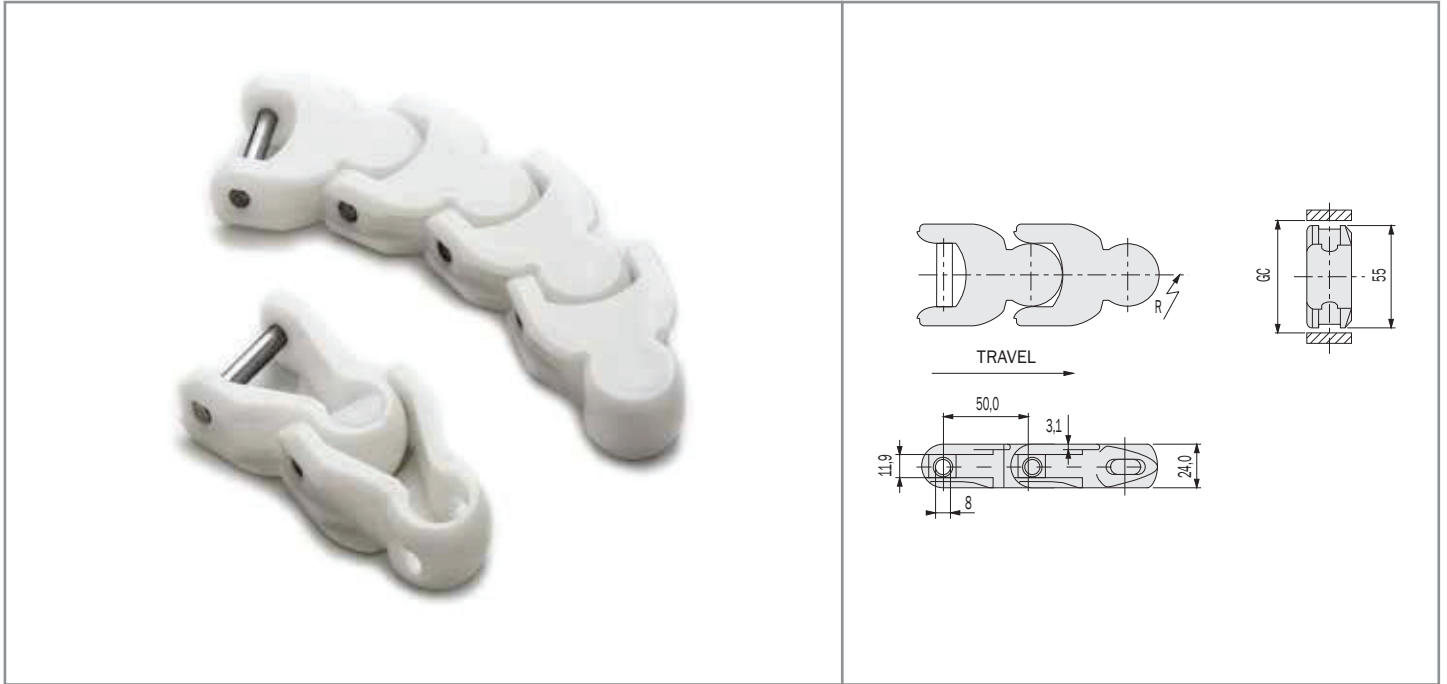

WLF 1500 - LOW FRICTION ACETAL RESIN

- Plates in self-lubricating, low friction acetal resin, white-coloured.
- Pins in austenitic chrome-nickel stainless steel, work hardened for high resistance.



PRODUCT CODE		INTERNAL CODE		CHARACTERISTICS		
		Radius R (mm)	GC st. (mm)	GC sid. (mm)	Working Load Max N (21°C)	Weight kg/m
WLF 1500	1500.WA	150	58	58	4000	1.37

- Standard shipping lengths = 122 pitches = 20 feet = 6,10 metres.

biplanar thermoplastic chains

1700 / 1700 TAB SERIES

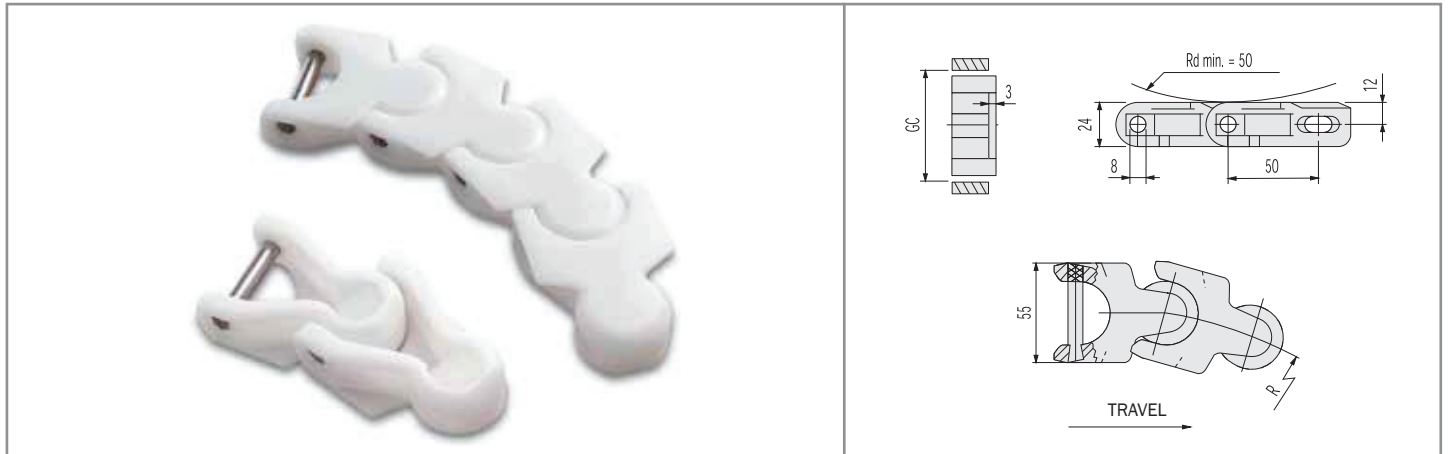

1700 - LOW FRICTION ACETAL RESIN

- Plates in self-lubricating low friction acetal resin
- Pins in austenitic chrome-nickel stainless steel, work hardened for high resistance.



p.195
p.213



p.227



p.231

PRODUCT CODE	INTERNAL CODE	CHARACTERISTICS				
	WHITE COLOUR	Radius R (mm)	GC st. (mm)	GC sid. (mm)	Working Load Max N (21°C)	Weight kg/m
WLF 1700	1700.WA	140	58	58	4000	1.26
	LIGHT BROWN COLOUR					
LFA 1700	1700.LFA	140	58	58	4000	1.26

- Standard shipping lengths = 122 pitches = 20 feet = 6,10 metres.

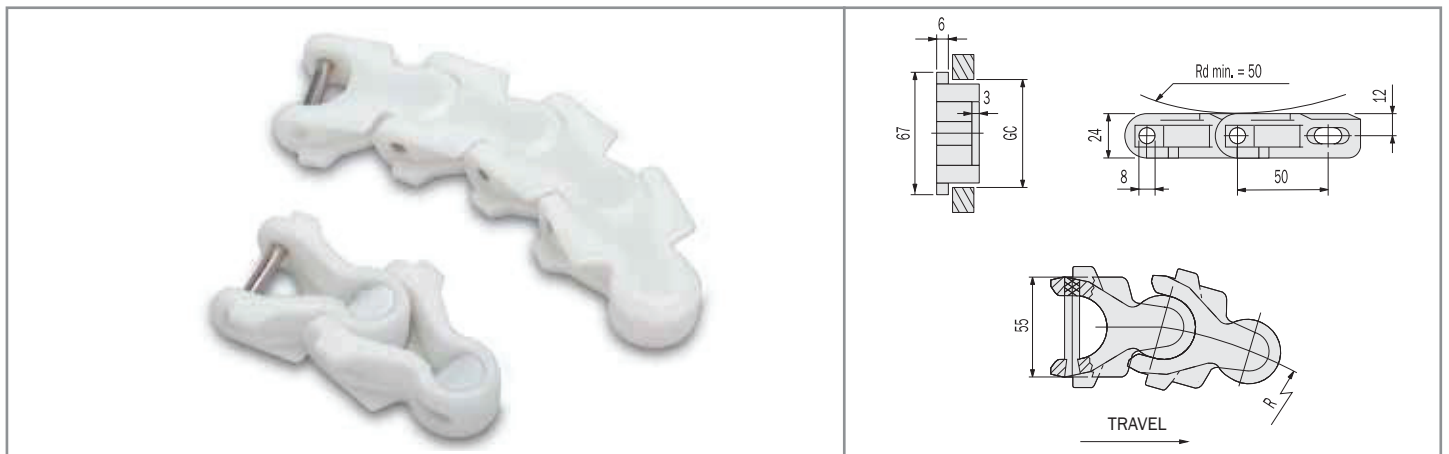

1700 TAB - LOW FRICTION ACETAL RESIN

- Plates in self-lubricating low friction acetal resin
- Pins in austenitic chrome-nickel stainless steel, work hardened for high resistance.



p.195
p.213



p.227



p.231

PRODUCT CODE	INTERNAL CODE	CHARACTERISTICS				
	WHITE COLOUR	Radius R (mm)	GC st. (mm)	GC sid. (mm)	Working Load Max N (21°C)	Weight kg/m
WLF 1700 TAB	1700TAB.WA	140	58	58	4000	1.30
	LIGHT BROWN COLOUR					
LFA 1700 TAB	1700TAB.LFA	140	58	58	4000	1.30

- Standard shipping lengths = 122 pitches = 20 feet = 6,10 metres.

biplanar thermoplastic chains

1701 / 1701 TAB SERIES



WLF 1701 - LOW FRICTION ACETAL RESIN

- Plates in self-lubricating low friction acetal resin, white coloured.
- Pins in austenitic chrome-nickel stainless steel, work hardened for high resistance.



p.195
p.213



upon
request

PRODUCT CODE	INTERNAL CODE	CHARACTERISTICS				
		Radius R (mm)	GC st. (mm)	GC sid. (mm)	Working Load Max N (21°C)	Weight kg/m
WLF 1701	1701.WA	150	62	60.3	4000	1.50

- Standard shipping lengths = 122 pitches = 20 feet = 6,10 metres.

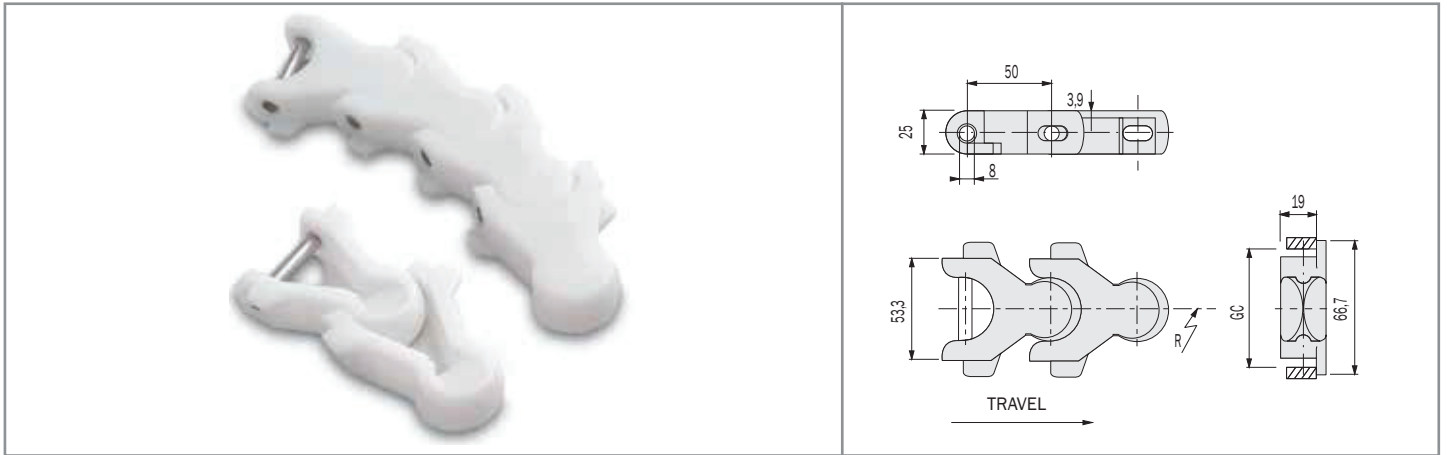

WLF 1701 TAB - LOW FRICTION ACETAL RESIN

- Plates in self-lubricating low friction acetal resin, white coloured.
- Pins in austenitic chrome-nickel stainless steel, work hardened for high resistance.



p.195
p.213



p.227



p.231

PRODUCT CODE	INTERNAL CODE	CHARACTERISTICS				
		Radius R (mm)	GC st. (mm)	GC sid. (mm)	Working Load Max N (21°C)	Weight kg/m
WLF 1701 TAB	1701.TAB.WA	150	57.5	56.0	4000	1.50

* If R > 500, GC = 55

- Standard shipping lengths = 122 pitches = 20 feet = 6,10 metres.

biplanar thermoplastic chains

1702 / 1703 SERIES

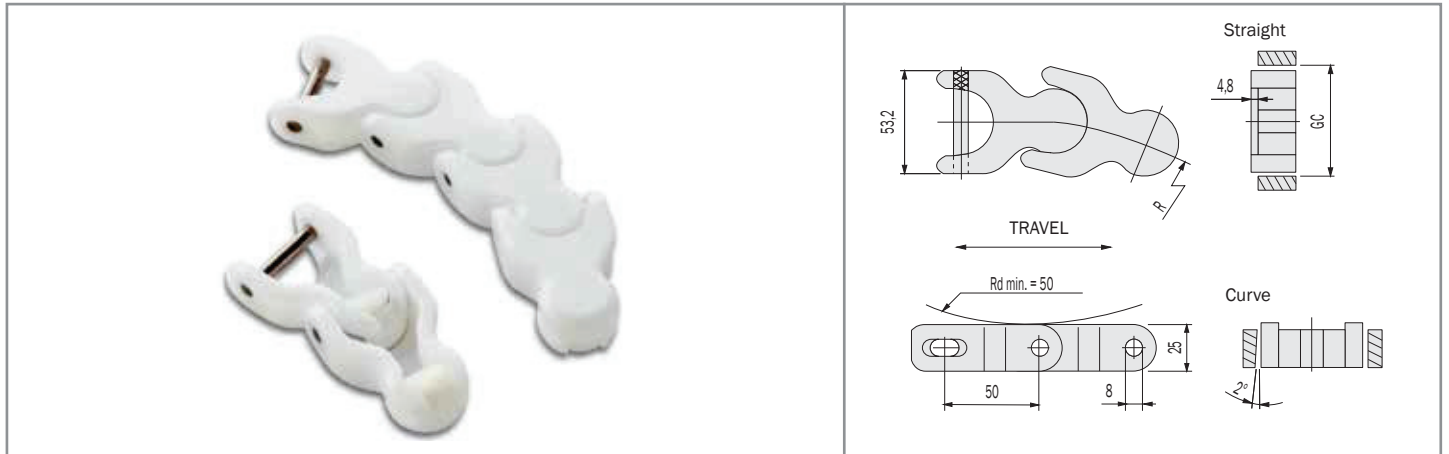

WLF 1702 - LOW FRICTION ACETAL RESIN

- Plates in self-lubricating low friction acetal resin, white coloured.
- Pins in austenitic chrome-nickel stainless steel, work hardened for high resistance.



p.195
p.213



upon
request



PRODUCT CODE	INTERNAL CODE	CHARACTERISTICS				
		Radius R (mm)	GC st. (mm)	GC sid. (mm)	Working Load Max N (21°C)	Weight kg/m
WLF 1702	1702.WA	140	59.5	56.8	4000	1.43

- Standard shipping lengths = 122 pitches = 20 feet = 6,10 metres.

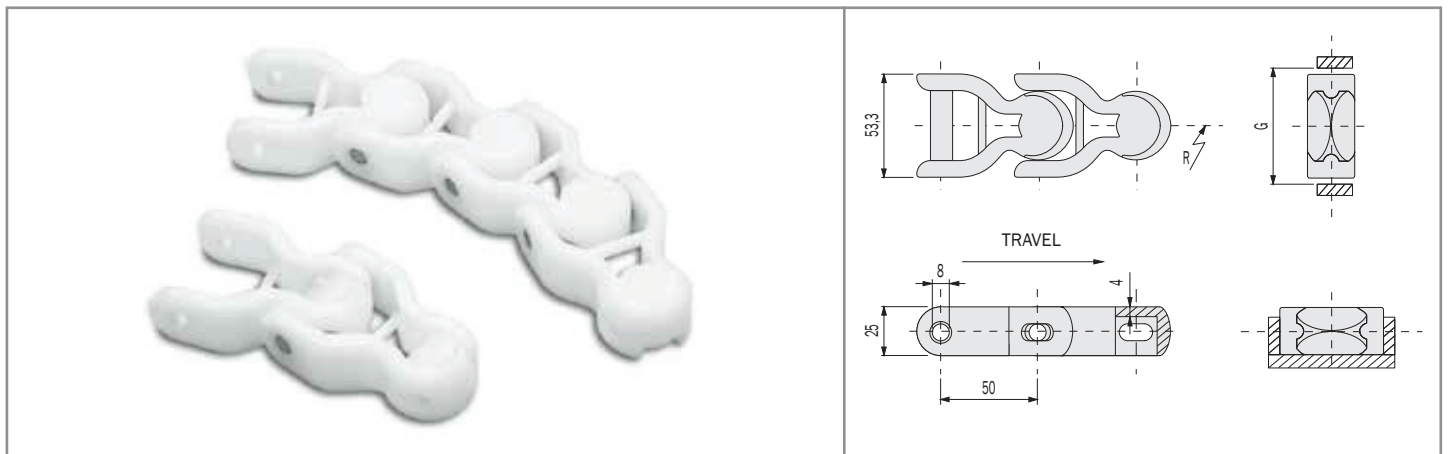

WLF 1703 - LOW FRICTION ACETAL RESIN

- Plates in self-lubricating low friction acetal resin, white coloured.
- The open design ensures optimum cleaning possibilities.
- Pins in austenitic chrome-nickel stainless steel, work hardened for high resistance.



p.195
p.213



upon
request



PRODUCT CODE	INTERNAL CODE	CHARACTERISTICS				
		Radius R (mm)	GC st. (mm)	GC sid. (mm)	Working Load Max N (21°C)	Weight kg/m
WLF 1703	1703.WA	150	58.7	56.9	4000	1.43

- Standard shipping lengths = 122 pitches = 20 feet = 6,10 metres.

biplanar thermoplastic chains accessories

CHAIN PEGS



AVAILABLE FOR - 1500, 1700, 1700 TAB,
1701, 1701 TAB, 1702, 1703 SERIES

• Pegs in self-lubricating low friction acetal resin or Polypropylene, white coloured.

PRODUCT CODE	INTERNAL CODE
Code biplanar thermoplastic chains + M	Ex: 1702.WA.M

- When ordering, please state the required distance between the pegs.

case conveyor chains

D 600 / D 600 C SERIES

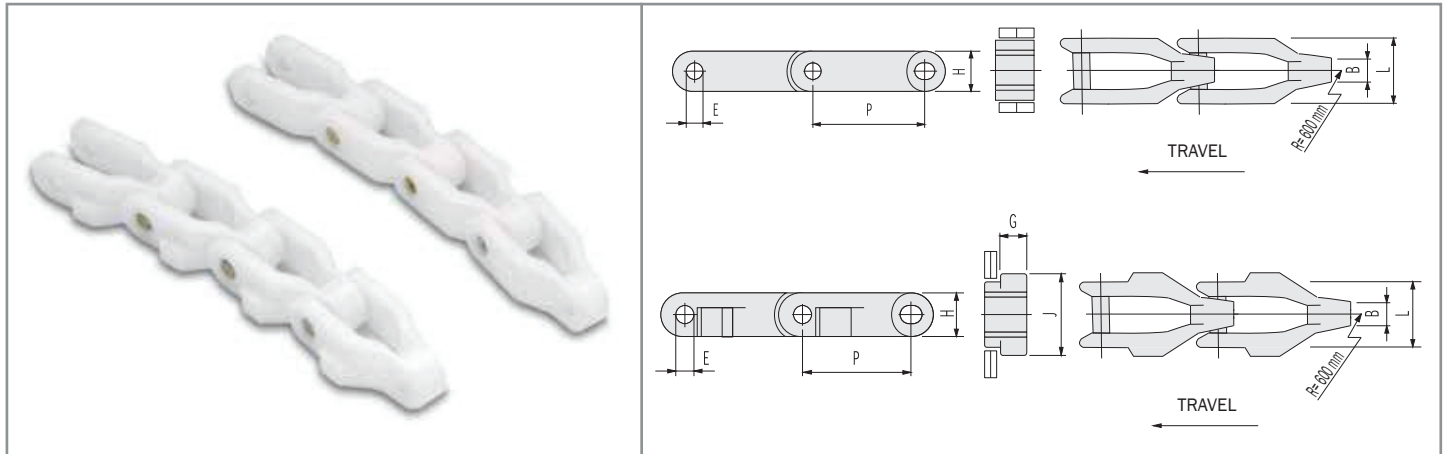

D 600 - D 600 TAB - ACETAL RESIN

- Plates in self-lubricating acetal resin, white coloured.
- Pins in austenitic chrome-nickel stainless steel, work hardened for high resistance.



p.198
p.213

PRODUCT CODE	INTERNAL CODE	CHARACTERISTICS									
		Pich P (mm)	L (mm)	Diam. E (mm)	B (mm)	H (mm)	J (mm)	G (mm)	Work. Load Max N (21°C)	Weight kg/m	
D 600	600.D	63.5	43	11.0	18.0	28.5	-	-	6000	1.44	
	TAB										
D 600 TAB	600.TAB.D.	63.5	43	11.0	18.0	28.5	54	14	6000	1.49	

- Standard shipping lengths = 96 pitches = 20 feet = 6,096 metres.

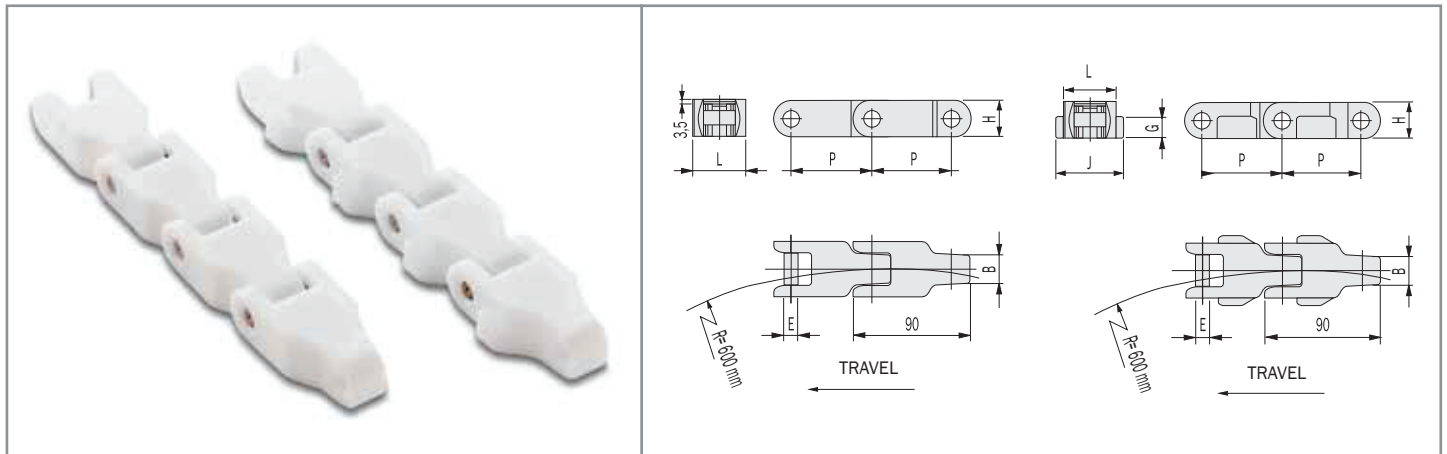

D 600 C - D 600 TAB C - ACETAL RESIN

- Plates in self-lubricating acetal resin, white coloured.
- Pins in austenitic chrome-nickel stainless steel, work hardened for high resistance.



p.198
p.213

PRODUCT CODE	INTERNAL CODE	CHARACTERISTICS									
		Pich P (mm)	L (mm)	Diam. E (mm)	B (mm)	H (mm)	J (mm)	G (mm)	Work. Load Max N (21°C)	Weight kg/m	
D 600 C	600.D.C	63.5	43	11.0	18.0	28.5	-	-	6000	1.42	
	TAB										
D 600 TAB C	600.TAB.D.C	63.5	43	11.0	18.0	28.5	54	14	6000	1.55	

- Standard shipping lengths = 96 pitches = 20 feet = 6,096 metres.

case conveyor chains

D 1400 SERIES

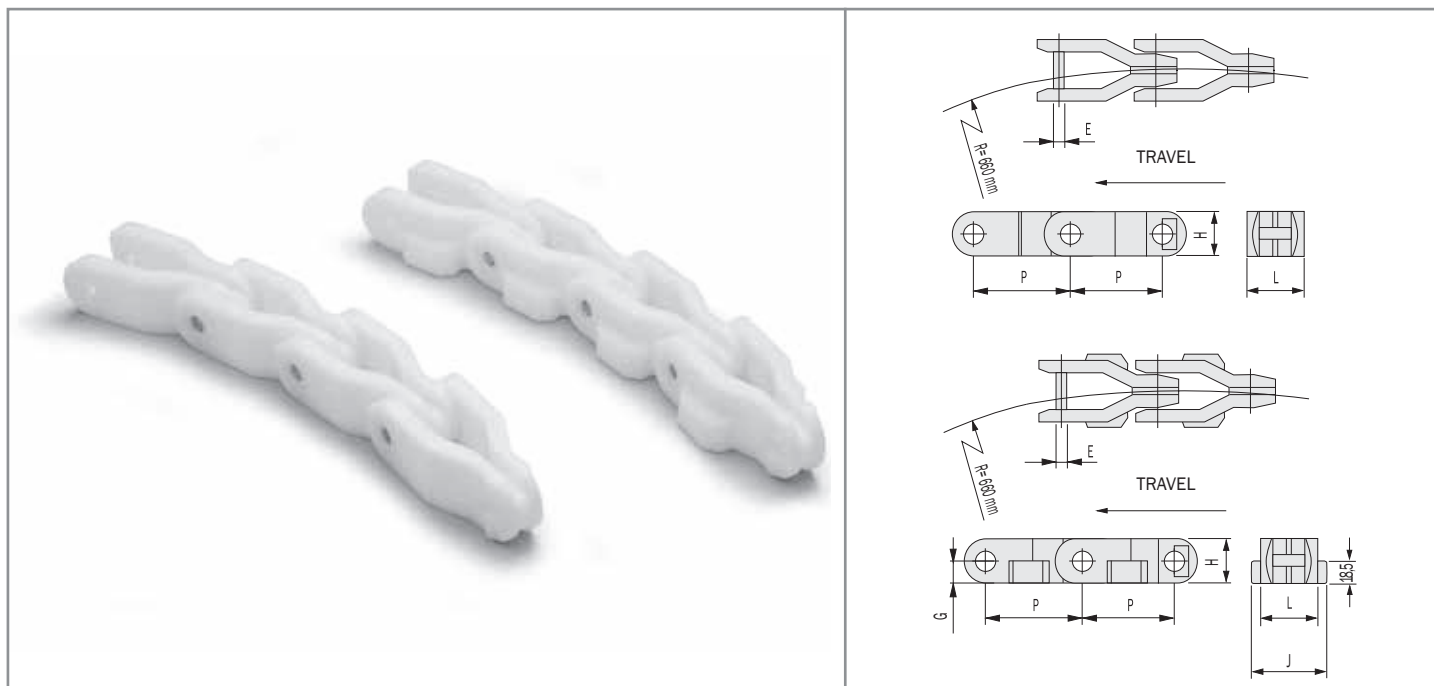

D 1400 - D 1400 TAB - ACETAL RESIN

- Plates in self-lubricating acetal resin, white coloured.
- Pins in austenitic chrome-nickel stainless steel, work hardened for high resistance.



p.199

PRODUCT CODE		INTERNAL CODE		CHARACTERISTICS					
		Pitch P (mm)	L (mm)	Diam. E (mm)	H (mm)	J (mm)	G (mm)	Work. Load Max N (21°C)	Weight kg/m
D 1400	1400.D	82.5	50	9.5	38.5	-	-	6000	1.44
	TAB								
D 1400 TAB	1400.TAB.D	82.5	50	9.5	38.5	66.0	19.25	6000	2.26

- Standard shipping lengths = 74 pitches = 20 feet = 6,105 metres.

thermoplastic straight runn. conveyor belts

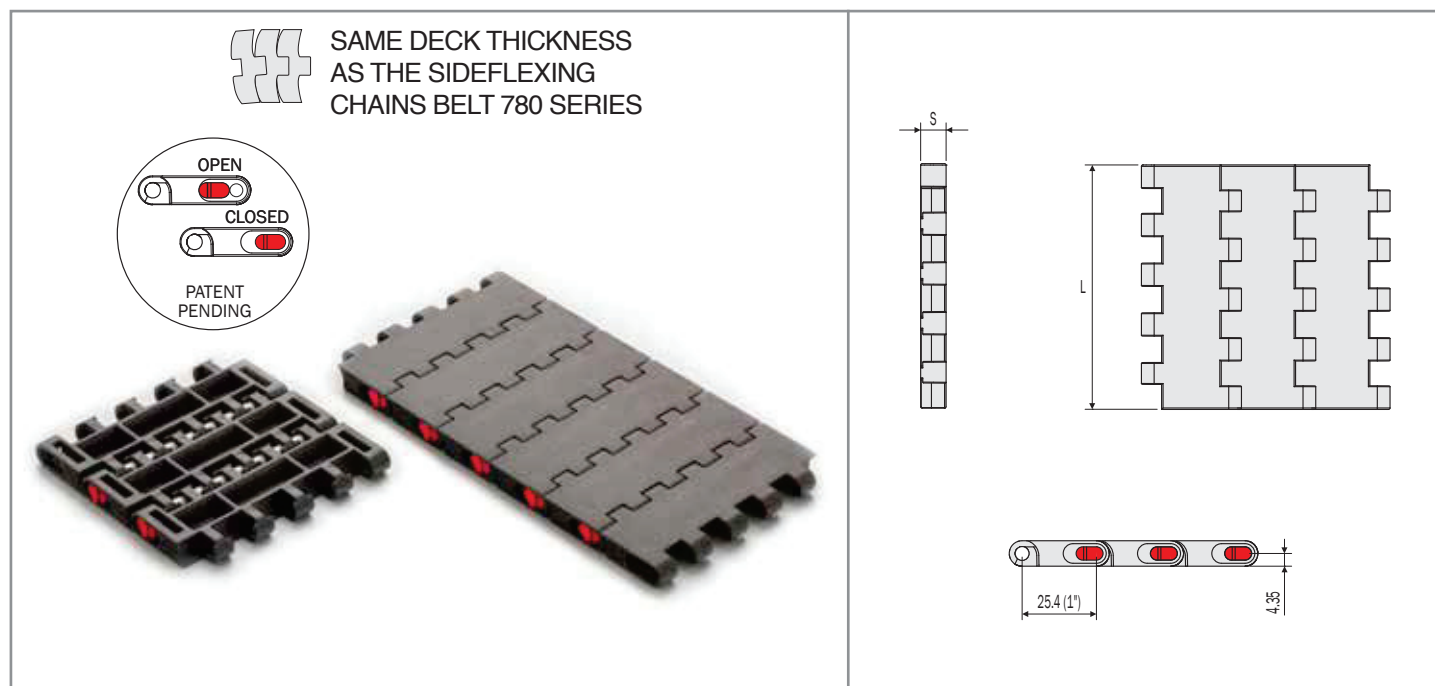
720 SERIES - NEW PIN LOCK SYSTEM



LFA 720 - LOW FRICTION ACETAL RESIN

- Plates in self-lubricating low friction acetal resin, light-brown or blue-coloured.
- Pins material: Pbt.



p.200



p.230
p.232

PRODUCT CODE	INTERNAL CODE	CHARACTERISTICS			
		Width L (mm)	Thickness S (mm)	Working Load Max N (21°C)	Weight kg/m
LFA 720 K325	9.10.040	82.5	8.7	25000	0.63
LFA 720 K330	9.10.042	83.8	8.7	25000	0.65
LFA 720 K335	9.10.050	85.0	8.7	25000	0.66
LFA 720 K450	9.10.080	114.3	8.7	25000	0.87

- Standard shipping lengths = 120 pitches = 10 feet = 3,048 metres.

SP 720 - SUPER PERFORMANCE ACETAL RESIN

- Plates in self-lubricating very low friction acetal resin, dark grey-coloured.
- Pins material: Pbt.



p.200



p.230
p.232

PRODUCT CODE	INTERNAL CODE	CHARACTERISTICS			
		Width L (mm)	Thickness S (mm)	Working Load Max N (21°C)	Weight kg/m
SP 720 K325	9.20.040	82.5	8.7	25000	0.63
SP 720 K330	9.20.042	83.8	8.7	25000	0.65
SP 720 K335	9.20.050	85.0	8.7	25000	0.66
SP 720 K450	9.20.080	114.3	8.7	25000	0.87

- Standard shipping lengths = 120 pitches = 10 feet = 3,048 metres.

- Available also in:
- WRX** material black-colour (PA)
 - PBT** material green-colour (Polyester)
 - AK** material dark grey or (POM with aramidic fibers) yellow-colour
 - WAF** material white-colour (POM)
 - PPB** material white-colour (PP)

thermoplastic straight runn. conveyor belts

720 PT SERIES WITH TWO POSITIONERS - NEW PIN LOCK SYSTEM

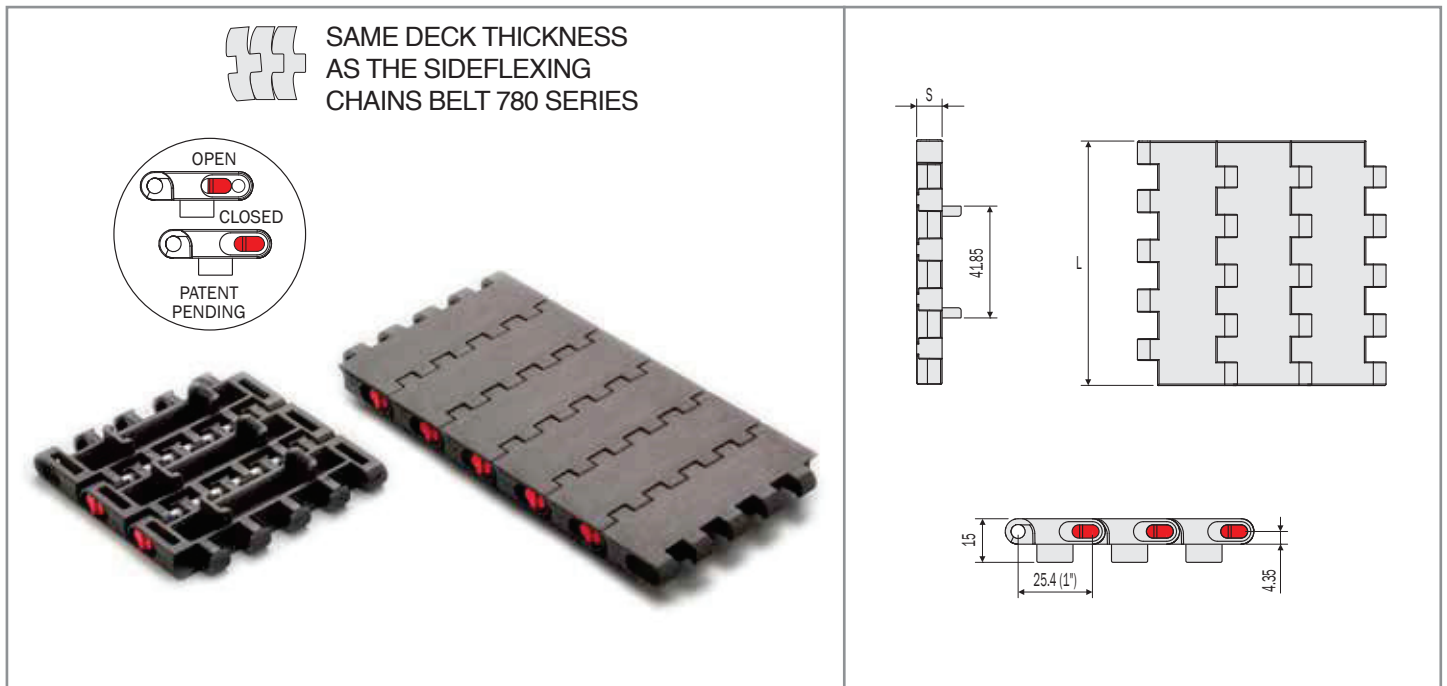

LFA 720 PT - LOW FRICTION ACETAL RESIN

- Plates in self-lubricating low friction acetal resin, light-brown or blue-coloured.
- Pins material: Pbt.

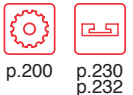

PRODUCT CODE	INTERNAL CODE	CHARACTERISTICS			
		Width L (mm)	Thickness S (mm)	Working Load Max N (21°C)	Weight kg/m
LFA 720 PT K325	9.10.040PT	82.5	8.7	25000	0.64
LFA 720 PT K330	9.10.042PT	83.8	8.7	25000	0.66
LFA 720 PT K335	9.10.050PT	85.0	8.7	25000	0.67
LFA 720 PT K450	9.10.080PT	114.3	8.7	25000	0.88

- Standard shipping lengths = 120 pitches = 10 feet = 3,048 metres.

SP 720 PT - SUPER PERFORMANCE ACETAL RESIN

- Plates in self-lubricating very low friction acetal resin, dark grey-coloured.
- Pins material: Pbt.

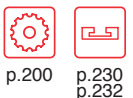

PRODUCT CODE	INTERNAL CODE	CHARACTERISTICS			
		Width L (mm)	Thickness S (mm)	Working Load Max N (21°C)	Weight kg/m
SP 720 PT K325	9.20.040PT	82.5	8.7	25000	0.64
SP 720 PT K330	9.20.042PT	83.8	8.7	25000	0.66
SP 720 PT K335	9.20.050PT	85.0	8.7	25000	0.67
SP 720 PT K450	9.20.080PT	114.3	8.7	25000	0.88

- Standard shipping lengths = 120 pitches = 10 feet = 3,048 metres.

- Available also in:
- WRX** material black-colour (PA)
 - PBT** material green-colour (Polyester)
 - AK** material dark grey or (POM with aramidic fibers) yellow-colour
 - WAF** material white-colour (POM)
 - PPB** material white-colour (PP)

thermoplastic straight runn. conveyor belts

730 SERIES - NEW PIN LOCK SYSTEM

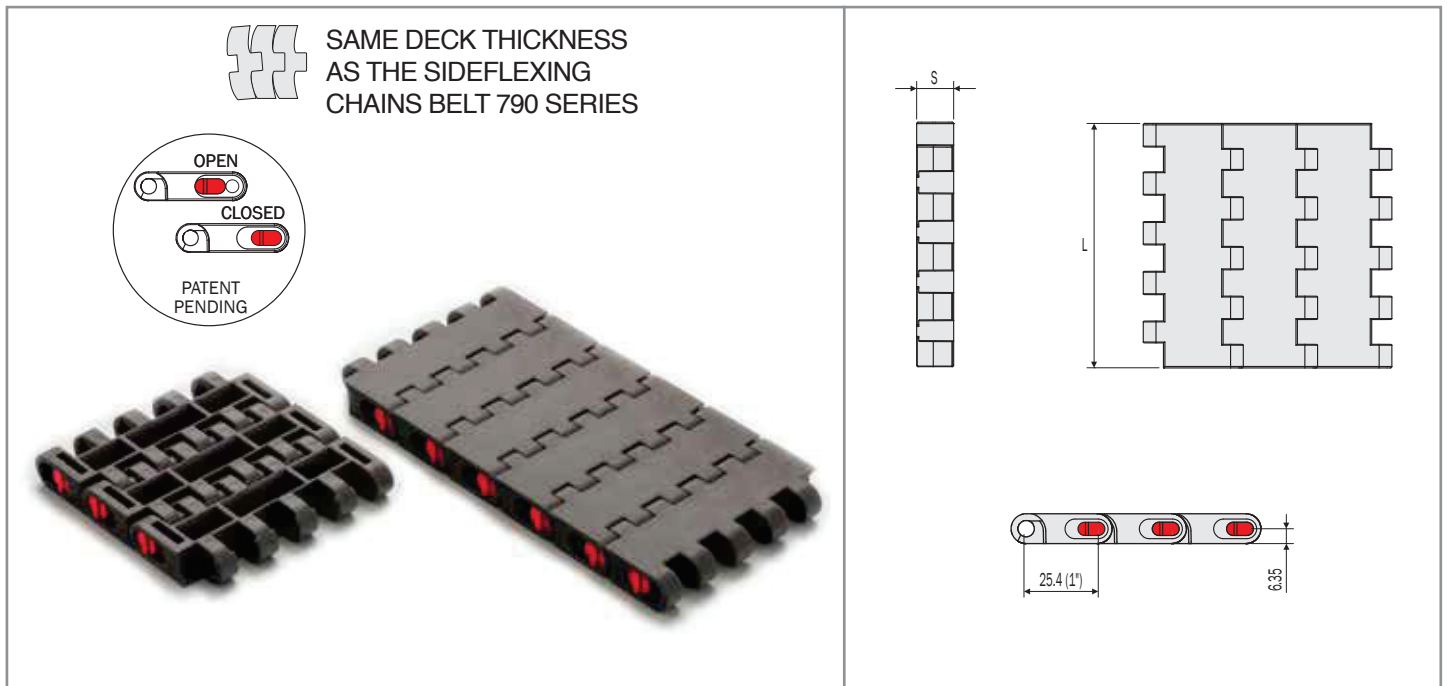

LFA 730 - LOW FRICTION ACETAL RESIN

- Plates in self-lubricating low friction acetal resin, light-brown or blue-coloured.
- Pins material: Pbt.

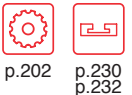

PRODUCT CODE	INTERNAL CODE	CHARACTERISTICS			
		Width L (mm)	Thickness S (mm)	Working Load Max N (21°C)	Weight kg/m
LFA 730 K325	9.11.040	82.5	12.7	38000	1.18
LFA 730 K330	9.11.042	83.8	12.7	38000	1.20
LFA 730 K335	9.11.050	85.0	12.7	38000	1.22
LFA 730 K450	9.11.080	114.3	12.7	38000	1.64

- Standard shipping lengths = 120 pitches = 10 feet = 3,048 metres.

SP 730 - SUPER PERFORMANCE ACETAL RESIN

- Plates in self-lubricating very low friction acetal resin, dark grey-coloured.
- Pins material: Pbt.

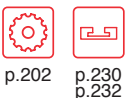

PRODUCT CODE	INTERNAL CODE	CHARACTERISTICS			
		Width L (mm)	Thickness S (mm)	Working Load Max N (21°C)	Weight kg/m
SP 730 K325	9.21.040	82.5	12.7	38000	1.18
SP 730 K330	9.21.042	83.8	12.7	38000	1.20
SP 730 K335	9.21.050	85.0	12.7	38000	1.22
SP 730 K450	9.21.080	114.3	12.7	38000	1.64

- Standard shipping lengths = 120 pitches = 10 feet = 3,048 metres.

- Available also in:
- WRX** material black-colour (PA)
 - PBT** material green-colour (Polyester)
 - AK** material dark grey or (POM with aramidic fibers) yellow-colour
 - WAF** material white-colour (POM)
 - PPB** material white-colour (PP)

thermoplastic straight runn. conveyor belts

730 PT SERIES WITH TWO POSITIONERS - NEW PIN LOCK SYSTEM

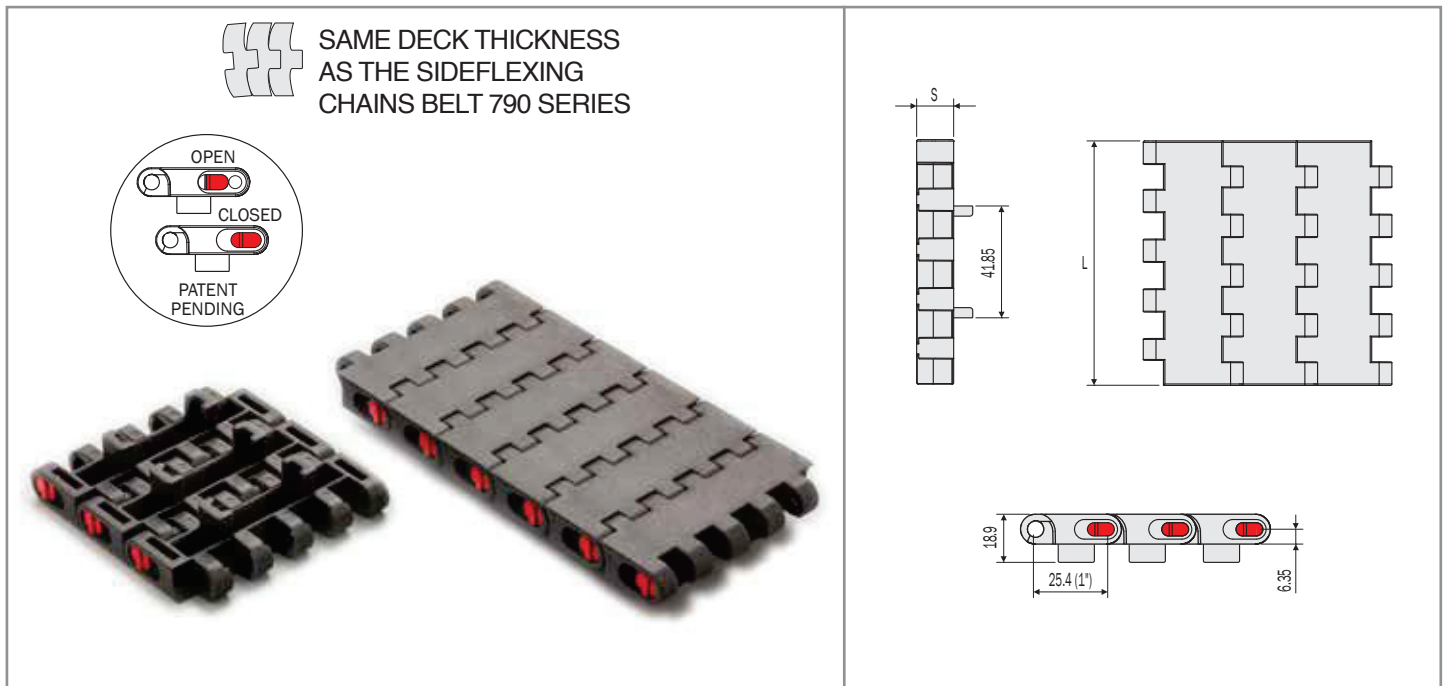

LFA 730 PT - LOW FRICTION ACETAL RESIN

- Plates in self-lubricating low friction acetal resin, light-brown or blue-coloured.
- Pins material: Pbt.

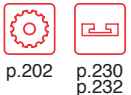

PRODUCT CODE	INTERNAL CODE	CHARACTERISTICS			
		Width L (mm)	Thickness S (mm)	Working Load Max N (21°C)	Weight kg/m
LFA 730 PT K325	9.11.040PT	82.5	12.7	38000	1.19
LFA 730 PT K330	9.11.042PT	83.8	12.7	38000	1.21
LFA 730 PT K335	9.11.050PT	85.0	12.7	38000	1.23
LFA 730 PT K450	9.11.080PT	114.3	12.7	38000	1.65

- Standard shipping lengths = 120 pitches = 10 feet = 3,048 metres.

SP 730 PT - SUPER PERFORMANCE ACETAL RESIN

- Plates in self-lubricating very low friction acetal resin, dark grey-coloured.
- Pins material: Pbt.

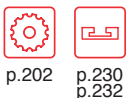

PRODUCT CODE	INTERNAL CODE	CHARACTERISTICS			
		Width L (mm)	Thickness S (mm)	Working Load Max N (21°C)	Weight kg/m
SP 730 PT K325	9.21.040PT	82.5	12.7	38000	1.19
SP 730 PT K330	9.21.042PT	83.8	12.7	38000	1.21
SP 730 PT K335	9.21.050PT	85.0	12.7	38000	1.23
SP 730 PT K450	9.21.080PT	114.3	12.7	38000	1.65

- Standard shipping lengths = 120 pitches = 10 feet = 3,048 metres.

- Available also in:
- WRX** material black-colour (PA)
 - PBT** material green-colour (Polyester)
 - AK** material dark grey or (POM with aramidic fibers) yellow-colour
 - WAF** material white-colour (POM)
 - PPB** material white-colour (PP)

thermoplastic sideflexing chains

780 TAB SERIES

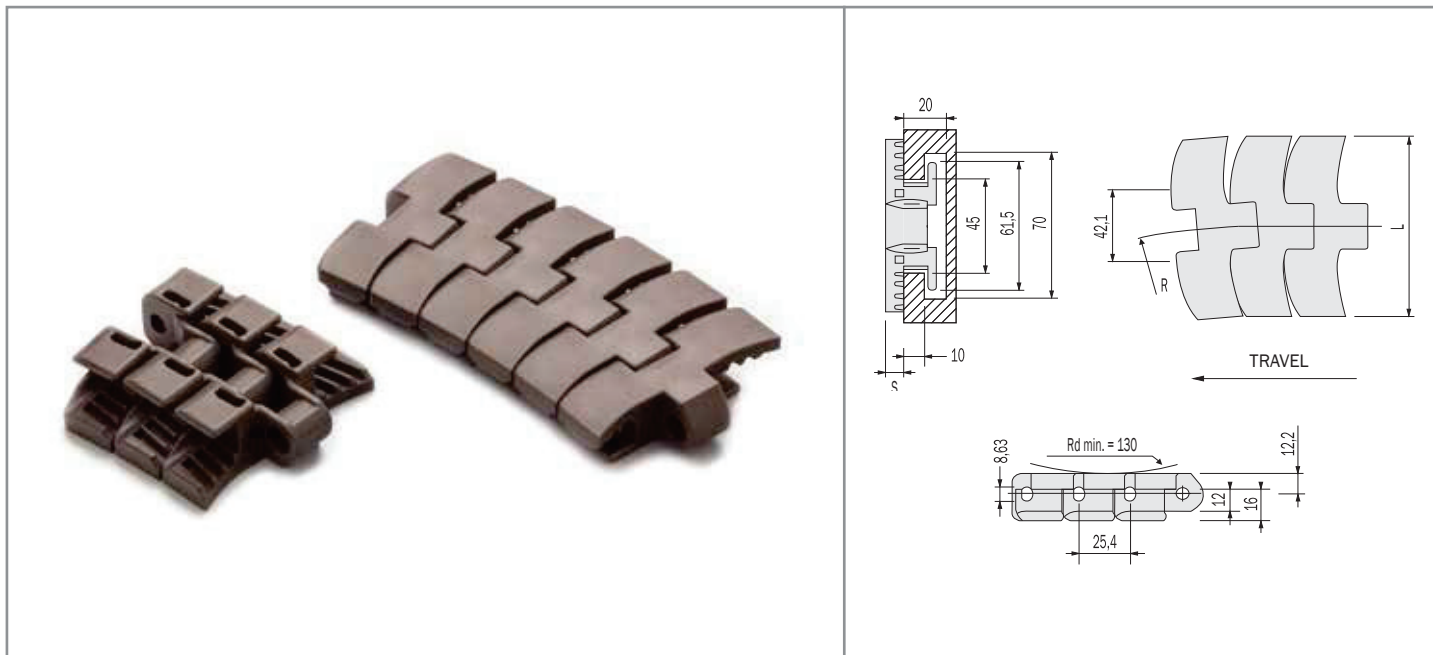

LFA 780 TAB - LOW FRICTION ACETAL RESIN

- Plates in self-lubricating low friction acetal resin, light brown or blue-coloured.
- Pins in special chrome-nickel stainless steel, work hardened for high resistance.



p.194



p.218



p.228

p.232

PRODUCT CODE	INTERNAL CODE	CHARACTERISTICS				
		Width L (mm)	S (mm)	Radius R (mm)	Working Load Max N (21°C)	Weight kg/m
LFA 780 TAB K330	9.12.042	83.8	8.7	500	2000	1.93
LFA 780 TAB K450	9.12.081	114.3	8.7	500	2000	2.20

- Standard shipping lengths = 120 pitches = 10 feet = 3,048 metres.
- These chains can be supplied with pins in austenitic stainless steel, work hardened, highly wear resistant.

SP 780 TAB - SUPER PERFORMANCE ACETAL RESIN

- Plates in self-lubricating very low friction acetal resin, dark grey-coloured.
- Pins in special chrome-nickel stainless steel, work hardened for high resistance.



p.194



p.218



p.228

p.232

PRODUCT CODE	INTERNAL CODE	CHARACTERISTICS				
		Width L (mm)	S (mm)	Radius R (mm)	Working Load Max N (21°C)	Weight kg/m
SP 780 TAB K330	9.22.042	83.8	8.7	500	2000	1.93
SP 780 TAB K450	9.22.081	114.3	8.7	500	2000	2.20

- Standard shipping lengths = 120 pitches = 10 feet = 3,048 metres.
- These chains can be supplied with pins in austenitic stainless steel, work hardened, highly wear resistant.

thermoplastic sideflexing chains

790 TAB SERIES

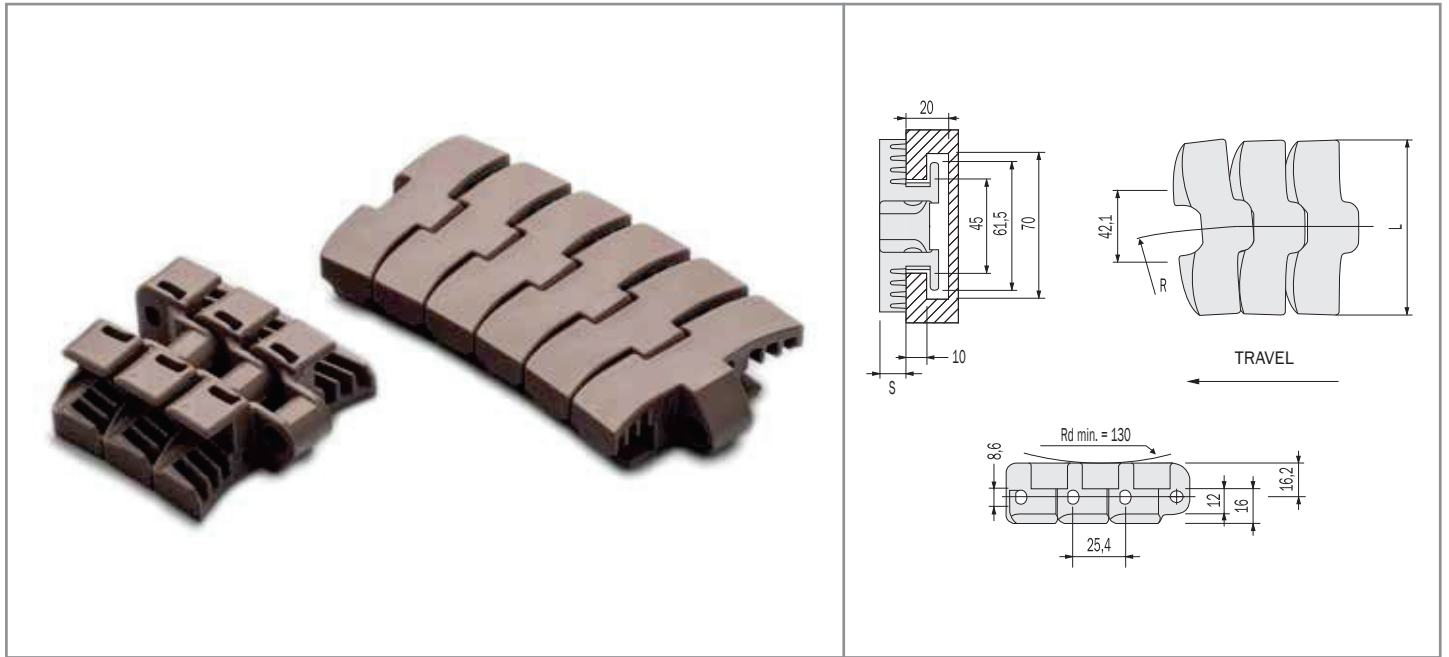

LFA 790 TAB - LOW FRICTION ACETAL RESIN

- Plates in self-lubricating low friction acetal resin, light brown-coloured.
- Pins in special chrome-nickel stainless steel, work hardened for high resistance.



p.194



p.218



p.228

p.232

PRODUCT CODE		INTERNAL CODE		CHARACTERISTICS		
		Width L (mm)	S (mm)	Radius R (mm)	Working Load Max N (21°C)	Weight kg/m
LFA 790 TAB K330	9.15.042	83.8	12.7	500	2200	2.13
LFA 790 TAB K450	9.15.081	114.3	12.7	500	2200	2.42

- Standard shipping lengths = 120 pitches = 10 feet = 3,048 metres.
- These chains can be supplied with pins in austenitic stainless steel, work hardened, highly wear resistant.

SP 790 TAB - SUPER PERFORMANCE ACETAL RESIN

- Plates in self-lubricating very low friction acetal resin, dark grey-coloured.
- Pins in special chrome-nickel stainless steel, work hardened for high resistance.



p.194



p.218



p.228

p.232

PRODUCT CODE		INTERNAL CODE		CHARACTERISTICS		
		Width L (mm)	S (mm)	Radius R (mm)	Working Load Max N (21°C)	Weight kg/m
SP 790 TAB K330	9.25.042	83.8	12.7	500	2200	2.13
SP 790 TAB K450	9.25.081	114.3	12.7	500	2200	2.42

- Standard shipping lengths = 120 pitches = 10 feet = 3,048 metres.
- These chains can be supplied with pins in austenitic stainless steel, work hardened, highly wear resistant.

thermoplastic sideflexing chains

ON MAGNETIC TRACKS - 780 M SERIES

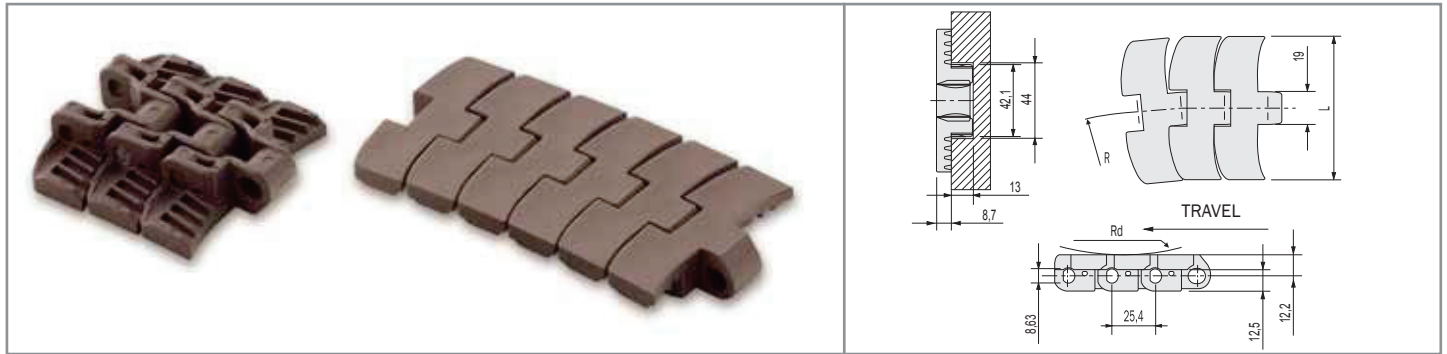

LFA 780 M - LOW FRICTION ACETAL RESIN

- Plates in self-lubricating low friction acetal resin, light brown-coloured.
- Pins in special stainless steel, 400 series, work hardened, magnetic, highly wear resistant.



PRODUCT CODE	INTERNAL CODE	CHARACTERISTICS				
		Width L (mm)	Rd (mm)	Radius R (mm)	Working Load Max N (21°C)	Weight kg/m
LFA 780 M K330	9.18.042	83.8	130	500	2000	1.68
LFA 780 M K450	9.18.080	114.3	130	500	2000	1.97

SP 780 M - SUPER PERFORMANCE ACETAL RESIN

- Plates in self-lubricating very low friction acetal resin, dark grey-coloured.
- Pins in special stainless steel, 400 series, work hardened, magnetic, highly wear resistant.



PRODUCT CODE	INTERNAL CODE	CHARACTERISTICS				
		Width L (mm)	Rd (mm)	Radius R (mm)	Working Load Max N (21°C)	Weight kg/m
SP 780 M K330	9.28.042	83.8	130	500	2000	1.68
SP 780 M K450	9.28.080	114.3	130	500	2000	1.97

WRX 780 M - WEAR RESISTANT POLYAMIDE COMPOSITE

- Plates in thermoplastic wear resistant polyamide composite, black-coloured.
- Pins in special stainless steel, 400 series, work hardened, magnetic, highly wear resistant.



PRODUCT CODE	INTERNAL CODE	CHARACTERISTICS				
		Width L (mm)	Rd (mm)	Radius R (mm)	Working Load Max N (21°C)	Weight kg/m
WRX 780 M K330	9.58.042	83.8	130	500	2000	1.68
WRX 780 M K450	9.58.080	114.3	130	500	2000	1.97

AK 780 M - HIGH WEAR RESISTANT ACETAL RESIN

- Plates in a very special acetal resin with aramidic fibers, dark grey-coloured.
- Pins in special stainless steel, 400 series, work hardened, magnetic, highly wear resistant.

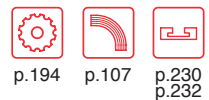

PRODUCT CODE	INTERNAL CODE	CHARACTERISTICS				
		Width L (mm)	Rd (mm)	Radius R (mm)	Working Load Max N (21°C)	Weight kg/m
AK 780 M K330	9.88.042	83.8	130	500	2000	1.68
AK 780 M K450	9.88.080	114.3	130	500	2000	1.97

- Standard shipping lengths = 120 pitches = 10 feet = 3,048 metres.
- The above-mentioned chains can also be produced in special acetal resin, with aramidic fibers yellow-coloured. (FOR AK 780 M)

thermoplastic sideflexing chains

ON MAGNETIC TRACKS - 790 M SERIES

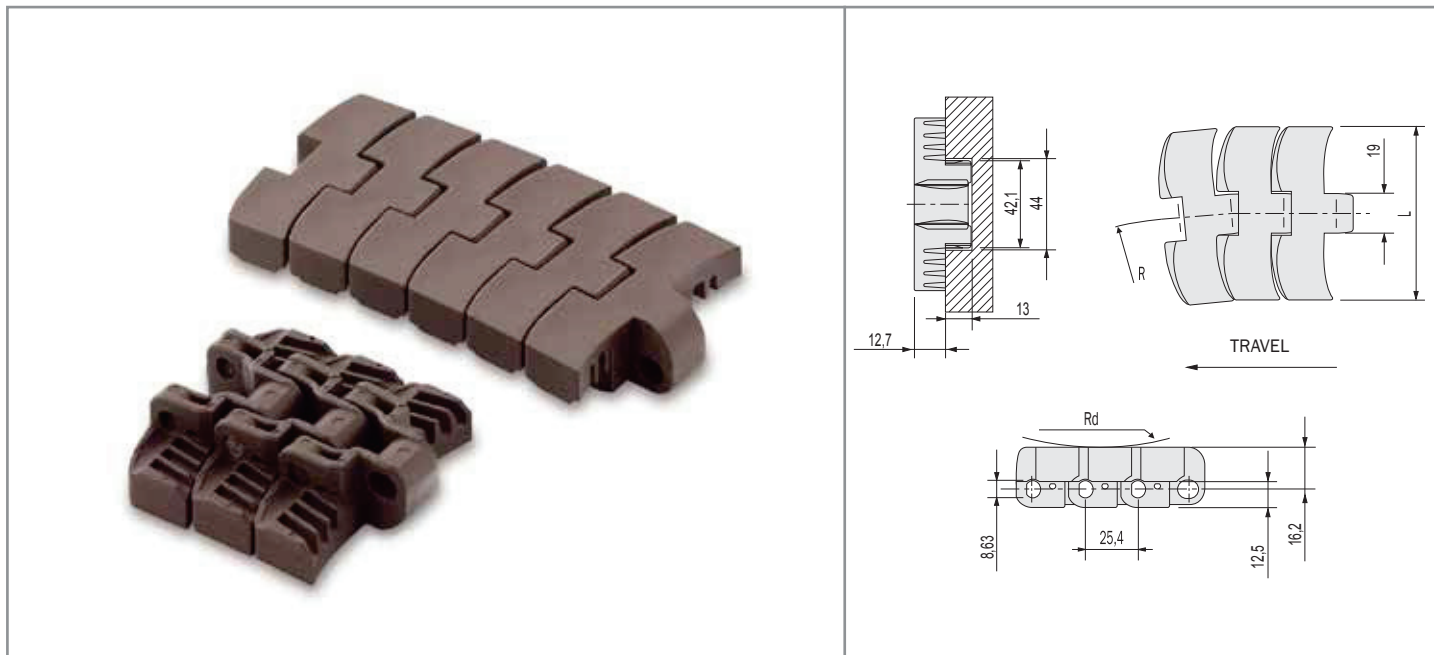

LFA 790 M - LOW FRICTION ACETAL RESIN

- Plates in self-lubricating low friction acetal resin, light brown-coloured.
- Pins in special stainless steel, 400 series, work hardened, magnetic, highly wear resistant.



p.194



p.107



p.230
p.232

PRODUCT CODE	INTERNAL CODE	CHARACTERISTICS				
		Width L (mm)	Rd (mm)	Radius R (mm)	Working Load Max N (21°C)	Weight kg/m
LFA 790 M K330	9.19.042	83.8	130	500	2200	1.68
LFA 790 M K450	9.19.080	114.3	130	500	2200	1.90

- Standard shipping lengths = 120 pitches = 10 feet = 3,048 metres.

SP 790 M - SUPER PERFORMANCE ACETAL RESIN

- Plates in self-lubricating very low friction acetal resin, dark grey-coloured.
- Pins in special stainless steel, 400 series, work hardened, magnetic, highly wear resistant.



p.194



p.107



p.230
p.232

PRODUCT CODE	INTERNAL CODE	CHARACTERISTICS				
		Width L (mm)	Rd (mm)	Radius R (mm)	Working Load Max N (21°C)	Weight kg/m
SP 790 M K330	9.29.042	83.8	130	500	2200	1.68
SP 790 M K450	9.29.080	114.3	130	500	2200	1.90

- Standard shipping lengths = 120 pitches = 10 feet = 3,048 metres.

thermoplastic sideflexing chains

ON MAGNETIC TRACKS - 780 MFG SERIES

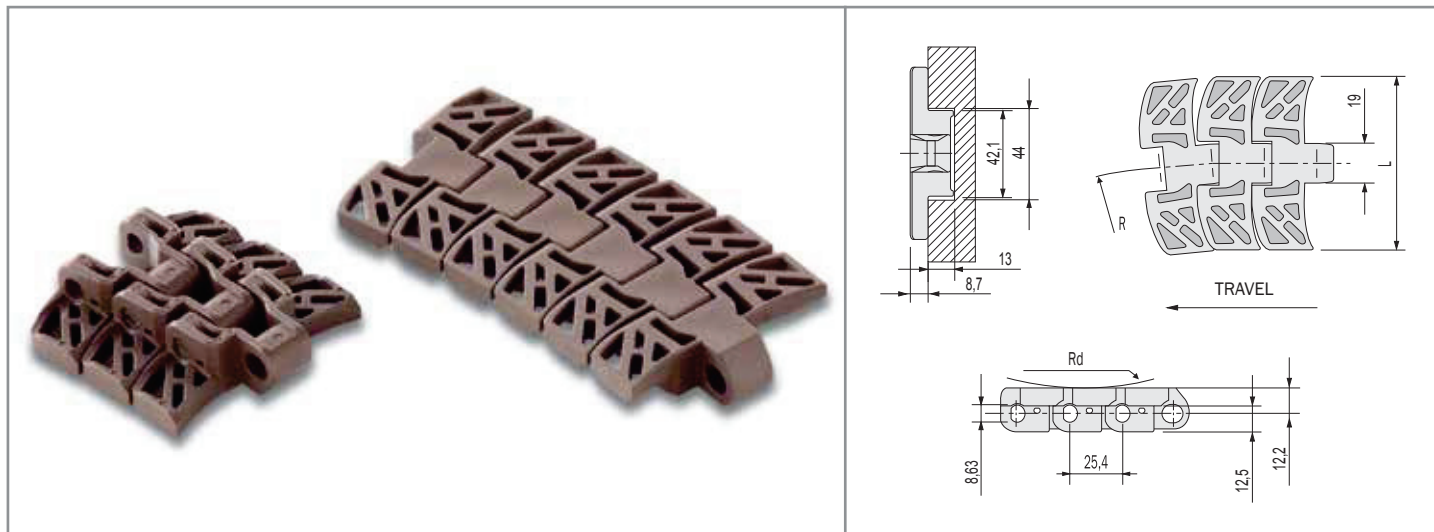

LFA 780 MFG - LOW FRICTION ACETAL RESIN

- Plates in self-lubricating low friction acetal resin, light brown-coloured.
- Pins in special stainless steel, 400 series, work hardened, magnetic, highly wear resistant.

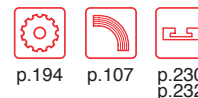

p.194 p.107 p.230
p.232

PRODUCT CODE	INTERNAL CODE	CHARACTERISTICS				
		Width L (mm)	Rd (mm)	Radius R (mm)	Working Load Max N (21°C)	Weight kg/m
LFA 780 MFG K330	9.18.242	83.8	130	500	1900	1.54

SP 780 MFG - SUPER PERFORMANCE ACETAL RESIN

- Plates in self-lubricating very low friction acetal resin, dark grey-coloured.
- Pins in special stainless steel, 400 series, work hardened, magnetic, highly wear resistant.



p.194 p.107 p.230
p.232

PRODUCT CODE	INTERNAL CODE	CHARACTERISTICS				
		Width L (mm)	Rd (mm)	Radius R (mm)	Working Load Max N (21°C)	Weight kg/m
SP 780 MFG K330	9.28.242	83.8	130	500	1900	1.54

WRX 780 MFG - WEAR RESISTANT POLYAMIDE COMPOSITE

- Plates in thermoplastic wear resistant polyamide composite, black-coloured.
- Pins in special stainless steel, 400 series, work hardened, magnetic, highly wear resistant.

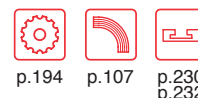

p.194 p.107 p.230
p.232

PRODUCT CODE	INTERNAL CODE	CHARACTERISTICS				
		Width L (mm)	Rd (mm)	Radius R (mm)	Working Load Max N (21°C)	Weight kg/m
WRX 780 MFG K330	9.58.242	83.8	130	500	1900	1.54

AK 780 MFG - HIGH WEAR RESISTANT ACETAL RESIN

- Plates in a very special acetal resin with aramidic fibers, dark grey-coloured.
- Pins in special stainless steel, 400 series, work hardened, magnetic, highly wear resistant.

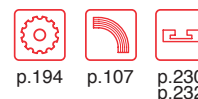

p.194 p.107 p.230
p.232

PRODUCT CODE	INTERNAL CODE	CHARACTERISTICS				
		Width L (mm)	Rd (mm)	Radius R (mm)	Working Load Max N (21°C)	Weight kg/m
AK 780 MFG K330	9.88.242	83.8	130	500	1900	1.54

- Standard shipping lengths = 120 pitches = 10 feet = 3,048 metres.
- The above-mentioned chains can also be produced in special acetal resin, with aramidic fibers yellow-coloured. (FOR AK 780 MFG)

thermoplastic sideflexing chains

780 TAB FG SERIES

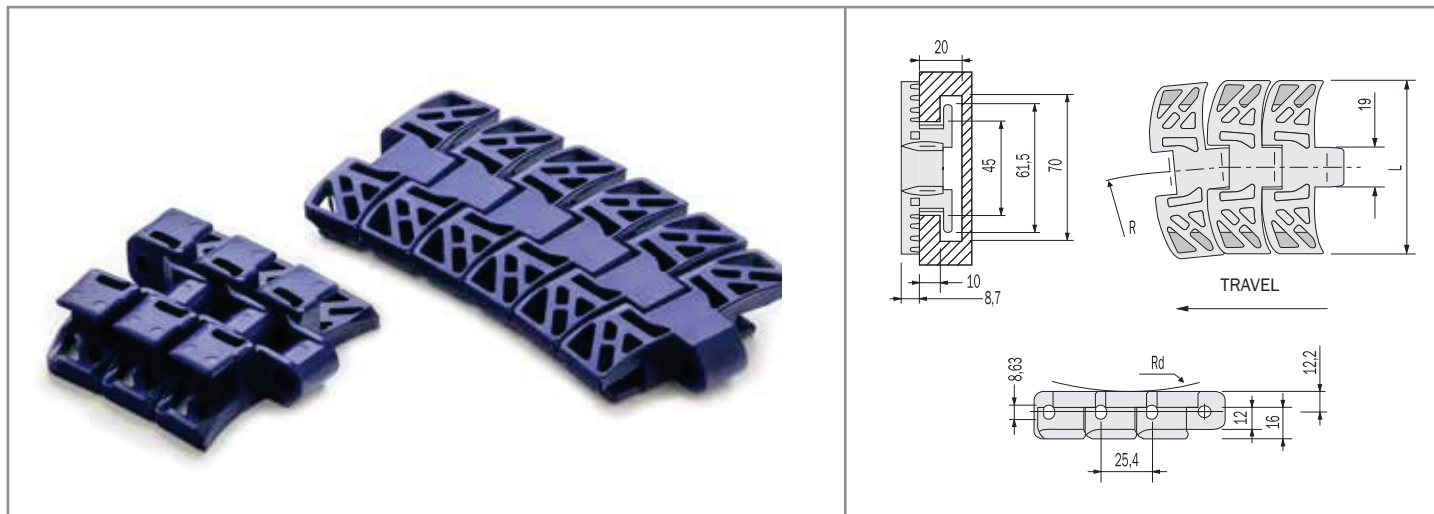

LFA 780 TAB FG - LOW FRICTION ACETAL RESIN

- Plates in self-lubricating low friction acetal resin, light brown-coloured.
- Pins in special stainless steel, work hardened, highly wear resistant.

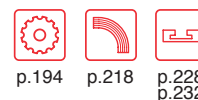

PRODUCT CODE	INTERNAL CODE	CHARACTERISTICS				
		Width L (mm)	Rd (mm)	Radius R (mm)	Working Load Max N (21°C)	Weight kg/m
LFA 780 TAB FG K330	9.12.242	83.8	130	500	1900	1.77

SP 780 TAB FG - SUPER PERFORMANCE ACETAL RESIN

- Plates in self-lubricating very low friction acetal resin, dark grey-coloured.
- Pins in special stainless steel, work hardened, highly wear resistant.

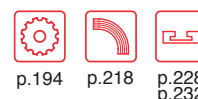

PRODUCT CODE	INTERNAL CODE	CHARACTERISTICS				
		Width L (mm)	Rd (mm)	Radius R (mm)	Working Load Max N (21°C)	Weight kg/m
SP 780 TAB FG K330	9.22.242	83.8	130	500	1900	1.77

WRX 780 TAB FG - WEAR RESISTANT POLYAMIDE COMPOSITE

- Plates in thermoplastic wear resistant polyamide composite, black-coloured.
- Pins in special stainless steel, work hardened, highly wear resistant.

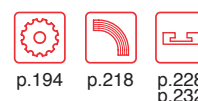

PRODUCT CODE	INTERNAL CODE	CHARACTERISTICS				
		Width L (mm)	Rd (mm)	Radius R (mm)	Working Load Max N (21°C)	Weight kg/m
WRX 780 TAB FG K330	9.52.242	83.8	130	500	1900	1.77

AK 780 TAB FG - HIGH WEAR RESISTANT ACETAL RESIN

- Plates in a very special acetal resin with aramidic fibers, dark grey-coloured.
- Pins in special stainless steel, work hardened, highly wear resistant.

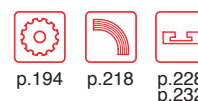

PRODUCT CODE	INTERNAL CODE	CHARACTERISTICS				
		Width L (mm)	Rd (mm)	Radius R (mm)	Working Load Max N (21°C)	Weight kg/m
AK 780 TAB FG K330	9.82.242	83.8	130	500	1900	1.77

- Standard shipping lengths = 120 pitches = 10 feet = 3,048 metres.
- The above-mentioned chains can also be produced in special acetal resin, with aramidic fibers yellow-coloured. (FOR AK 780 TAB FG)

plastic corrosion resistance table

LEGEND

- = Little resistance - not recommended
- = Average resistance
- = Good resistance - it can be used

CHEMICAL AGENT	ACETAL RESIN D	ACETAL RESIN LFA / WLF	ACETAL RESIN SP / AK	POLYAMIDE COMPOSITE WRX	ANTISTATIC RESIN AS	POLYPROPYLENE PPB	POLYESTER PBT
A Acetic acid	○	○	○	○	○	●●	●●
Acetone	●	●	●	●●	●	●●	●
Aluminium chloride	○	○	○	●●	○	○	-
Ammonia	●●	●●	●●	●●	●●	●●	●
Ammonium chloride	○	○	○	●●	○	○	-
Amyl alcohol	○	○	○	●●	○	●●	-
Aniline	●●	●●	●●	●	●●	●●	-
B Beer	●●	●●	●●	●●	●●	●●	●●
Benzene	●●	●●	●●	●●	●●	●●	○
Benzoic acid	○	○	○	●	○	●●	-
Benzol	●●	●●	●●	●●	●●	●●	●●
Boric acid	●●	●●	●●	●●	●●	●●	-
Brine	●	●	●	●	●	●●	-
Butter	●●	●●	●●	●●	●●	●●	-
Butyl alcohol	○	○	○	●	○	●●	-
Butyric acid	○	○	○	○	○	●●	-
C Calcium chloride	●	●	●	●●	●	●●	-
Carbon disulphide	●●	●●	●●	●●	●●	●●	-
Carbon tetrachloride	●●	●●	●●	●●	●●	○	-
Carbonated drinks	●●	●●	●●	●●	●●	○	-
Cheese	●●	●●	●●	○	●●	●●	-
Chlorine water	○	○	○	-	○	○	-
Chloroform	○	○	○	○	○	○	-
Citric acid	●	●	●	○	●	●●	●●
Copper sulphate	●●	●●	●●	-	●●	●●	-
D Diet oil	●●	●●	●●	-	●●	●●	-
Diet fat	●●	●●	●●	-	●●	●●	-
Distilled water	●●	●●	●●	●●	●●	●●	-
E Ethyl acetate	○	○	○	●●	○	●●	-
Ethyl alcohol	●●	●●	●●	●●	●●	●●	-
Ethyl chloride	●●	●●	●●	●●	●●	○	-
Ethyl ether	●●	●●	●●	●●	●●	●●	-
F Flax oil	○	○	○	●●	○	●●	-
Formaldehyde	●●	●●	●●	●●	●●	●●	-
Formic acid	○	○	○	○	○	●●	●
Freon 12	○	○	○	●●	○	○	-
Fresh water	●●	●●	●●	●●	●●	●●	●●
Fruit juice	●●	●●	●●	●●	●●	●●	●●
G Gasoline	●●	●●	●●	●●	●●	●	-
Glycerine	●●	●●	●●	●●	●●	●●	-
H Hydrochloric acid	○	○	○	○	○	●●	●
Hydrofluoric acid	○	○	○	○	○	●●	-
Hydrogen peroxide	○	○	○	○	○	●●	-
I Iodine	●●	●●	●●	○	●●	●●	-
Iron chloride	○	○	○	-	○	●●	-
L Lactid acid	●●	●●	●●	●●	●●	●●	●●
M Magnesium chloride	○	○	○	●●	○	●●	-
Mercury	●●	●●	●●	●●	●●	●●	-
Methyl alcohol	●●	●●	●●	●●	●●	●●	-
Methylene chloride	○	○	○	●●	○	●	-
Milk	●●	●●	●●	●●	●●	●●	●●
N Nitric acid	○	○	○	○	○	●●	○
O Oil	●●	●●	●●	●●	●●	●	○
Oil ether	●●	●●	●●	●●	●●	●●	-
Oleic acid	○	○	○	●●	○	●●	-
P Paraffin	●●	●●	●●	○	●●	●●	●●
Phenol	○	○	○	○	○	●●	-
Phosphoric acid	○	○	○	○	○	●●	●
Potassium hydroxine	○	○	○	●●	○	○	-
S Sea water	●	●	●	●●	●	●●	●●
Silicone oil	○	○	○	●●	○	●●	-
Silver nitrate	○	○	○	●●	○	●●	-
Soapy water	●●	●●	●●	●●	●●	●●	●●
Sodium carbonate	●●	●●	●●	●●	●●	●●	-
Sodium chloride	●●	●●	●●	●●	●●	●●	-
Sodium hydroxine	●●	●●	●●	●●	●●	●●	○
Sodium hypochlorite	○	○	○	●●	○	●●	●
Sodium silicate	○	○	○	●●	○	○	-
Sodium sulphate	●●	●●	●●	●●	●●	●●	-
Soft drinks	●●	●●	●●	●●	●●	●●	●●
Suds	○	○	○	●●	○	●●	-
Sulfuric acid	○	○	○	○	○	●●	●●
T Tartaric acid	●	●	●	●●	●	●●	-
Tetarline	○	○	○	●●	○	○	-
Tincture of iodine	●●	●●	●●	○	●●	●●	-
Transformer oil	○	○	○	●●	○	●	-
Trichlorethylene	○	○	○	○	○	○	-
Turpentine	○	○	○	●	○	○	●●
V Vegetable juice	●●	●●	●●	●●	●●	●●	●●
Vegetable oil	●●	●●	●●	●●	●●	●●	○
Vinegar	●●	●●	●●	●●	●●	●●	●●
W Whiskey	●●	●●	●●	●●	●●	●●	●●
Wine	●●	●●	●●	●●	●●	●●	●●
X Xilol	●●	●●	●●	●●	●●	○	●●
Z Zinc chloride	○	○	○	●	○	●●	-

VIA MONTE BIANCO 15/17
20833 GIUSSANO - MB

.....
INFO@MAPEC.NET
WWW.MAPEC.NET
T 0362 311684
F 0362311007