

# MAPEC

MOVING SOLUTIONS

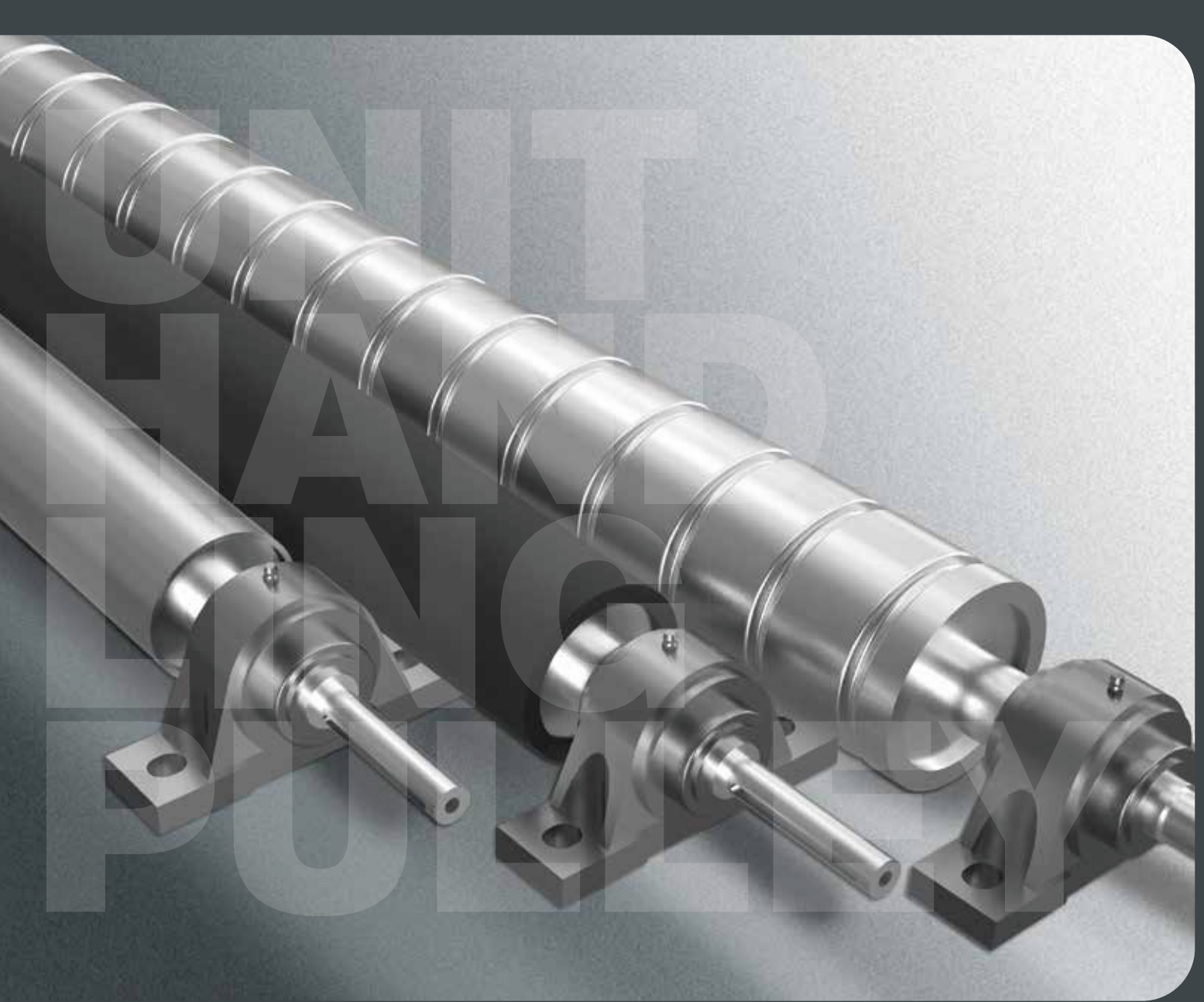



**PULLEYS  
AND ROLLERS**  
FOR UNIT HANDLING  
APPLICATIONS



**RULMECCA®**

MOVING AHEAD

## GLOBAL PRESENCE AND LOCAL SERVICE



 MANUFACTURING, SALES, SERVICE

 SALES, SERVICE

Australia	Italy
Canada	Poland
China	South Africa
Denmark / Sweden	Spain / Portugal
Finland	Thailand
France	Turkey
Germany	United Kingdom
India	USA
Indonesia	

### ABOUT RULMECA

Founded in 1962, the Rulmecca Group has grown to be a leading partner to the global materials handling industry. With its three product brands, Rulmecca, Precismeca and Melco, Rulmecca Group is the world's largest supplier of rollers, idlers, pulleys and motorized pulleys for heavy duty belt conveyors for quarries and mining applications and of Rollers, Drum Motors and 24V Drive Rollers for Intralogistics.

## BELT CONVEYORS FOR UNIT HANDLING APPLICATIONS



AIRPORT, SECURITY  
AND X-RAY SCREENING



POSTAL, PARCEL  
AND E-COMMERCE



MANUFACTURING,  
PACKAGING  
AND AUTOMATION



DISTRIBUTION CENTRES  
AND WAREHOUSING



# PULLEYS FOR UNIT HANDLING APPLICATIONS

**RULMECA PULLEYS FOR UNIT HANDLING APPLICATIONS ARE LIFE-LASTING PRODUCTS FOR BELT DRIVEN LOGISTIC APPLICATIONS.**

**THESE PRODUCTS HAVE BEEN ENGINEERED WITH ALL THE KNOWLEDGE AND KNOWHOW RULMECA GROUP HAS IN TERMS OF PERFORMANCE, PRECISION, TECHNOLOGY AND DURABILITY.**

**YEARS OF DEVELOPMENT IN WELDED AND UN-WELDED MARKETS PERMITTED RULMECA TO REACH THE HIGHEST MANUFACTURING LEVEL FOR THESE PRODUCTS.**



High quality structural steel tube\*, optimized for external diameter turning. Our pulley can reach the highest level of straightness and roundness, avoiding belt misalignments and keeping a low noise level;



Stub axles\*, best stress and wear solution at the lowest overall weight. Low eccentricity and concentricity merged with low roughness are the state of art of Rulmecca production technology;



Shrink fit: utilised to guarantee the highest constructive precision\*\* and stress distribution among all the elements of the structure, every single component is shrink fitted with the others;



Certified UNI EN ISO 15614 automatic weldings with components pre-heating. Rulmecca state of art in welding technology. This process guarantees the lowest level of residual stresses and the complete fusion of welded components;



Anti-abrasive rubber lagging, according to the severity of the application, Rulmecca can supply different types of abrasion resistant rubbers. To increase the traction between the pulley and belt, or to extend the life of the pulley there are many available options. Lagging is common and the choices are numerous. Materials such as SBR, neoprene, urethane, nitrile and EPDM may be selected to best meet specific chemical or environmental challenges encountered.

\*STANDARD MATERIALS  
(different materials on request)

TUBE: S355JR  
FLANGES: S355JR  
PINS: C40

\*\*STANDARD PRECISION  
(different precision on request)

TUBE: Ra 6.3  
PINS (bearings coupling diameter): h7, Ra 0.8  
ECCENTRICITY (ref. pins / pins and ref. pins/tube): 0.15 mm

# UNIT HANDLING PULLEYS

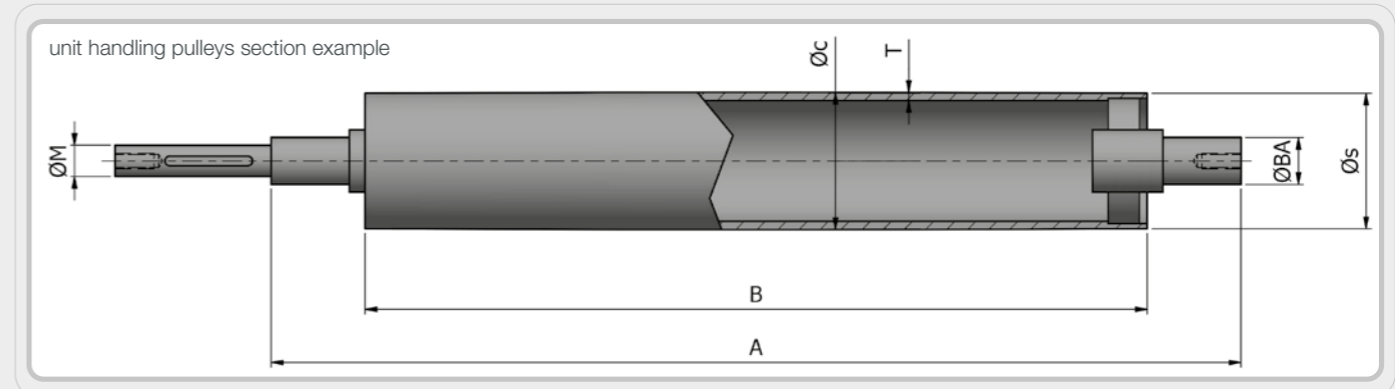

THANKS TO OUR EXPERIENCE WE ARE ABLE TO CUSTOMIZE THE PRODUCT ACCORDING TO THE CUSTOMER'S NEEDS



**STANDARD SIZES (S355JR TUBE AND FLANGES, C40 PINS)**

TUBE SIZE *	EXTERNAL DIAMETER ØC AT CENTER	SIDE DIAMETER ØS **	TUBE THICKNESS T AT CENTER	TUBE WEIGHT **	FLANGE THICKNESS		RAW DIAMETER ØR	BEARING DIAMETER ØBA	MOTOR DIAMETER ØM	REFERENCE PRODUCT WEIGHT (IDLER PULLEY)	
										A-B	WEIGHT
60 x 5 mm	59 mm	58,5 mm	4,5 mm +0.5/-0	0,006 Kg/mm	15 mm		30 mm	20 mm	According to customer gearbox	50 mm	0,80 Kg + tube weight mm
76 x 6 mm	74,5 mm	73,5 mm	5 mm +0.5/-0	0,002 Kg/mm	15 mm		35 mm	25 mm		35 mm	1,38 kg + tube weight mm
89 x 6 mm	87,5 mm	86,5 mm	5 mm +0.5/-0	0,011 Kg/mm	20 mm		40 mm	30 mm		100 mm	2,52 Kg + tube weight mm
89 x 8 mm	87,5 mm	86,5 mm	7 mm +0.5/-0	0,014 Kg/mm	20 mm		50 mm	40 mm		150 mm	3,78 Kg + tube weight mm
114 x 10 mm	112,5 mm	111,5 mm	9 mm +0.5/-0	0,023 Kg/mm	20 mm		50 mm	40 mm		150 mm	4,74 Kg + tube weight mm
133 x 8 mm	131,5 mm	130,5 mm	7 mm +0.5/-0	0,022 Kg/mm	20 mm		40 mm	30 mm		100 mm	4,87 Kg + tube weight mm
159 x 8 mm	157,5 mm	156,5 mm	7 mm +0.5/-0	0,027 Kg/mm	20 mm		40 mm	30 mm		100 mm	6,72 Kg + tube weight mm
168 x 10 mm	166 mm	164 mm	9 mm +0.5/-0	0,035 Kg/mm	20 mm		60 mm	50 mm		200 mm	10,26 Kg + tube weight mm

\*Other diameters and thicknesses available upon request. Rulmeca technical department is available to provide support, to select or co-design the right product for every application.

\*\* After machining

THANKS TO THE WIDE RANGE OF PRODUCTS AVAILABLE, WE ARE ABLE TO COVER ALL NEEDS IN TERMS OF SCOPE.

THANKS TO THE IN-DEPTH STUDY AND TESTS CARRIED OUT ON THE PRODUCT, THE LOADS ARE DEFINED WITH EXTREME PRECISION AND GUARANTEE THE HANDLING INDICATED IN THE TABLE. FINITE ELEMENT METHOD (FEM)

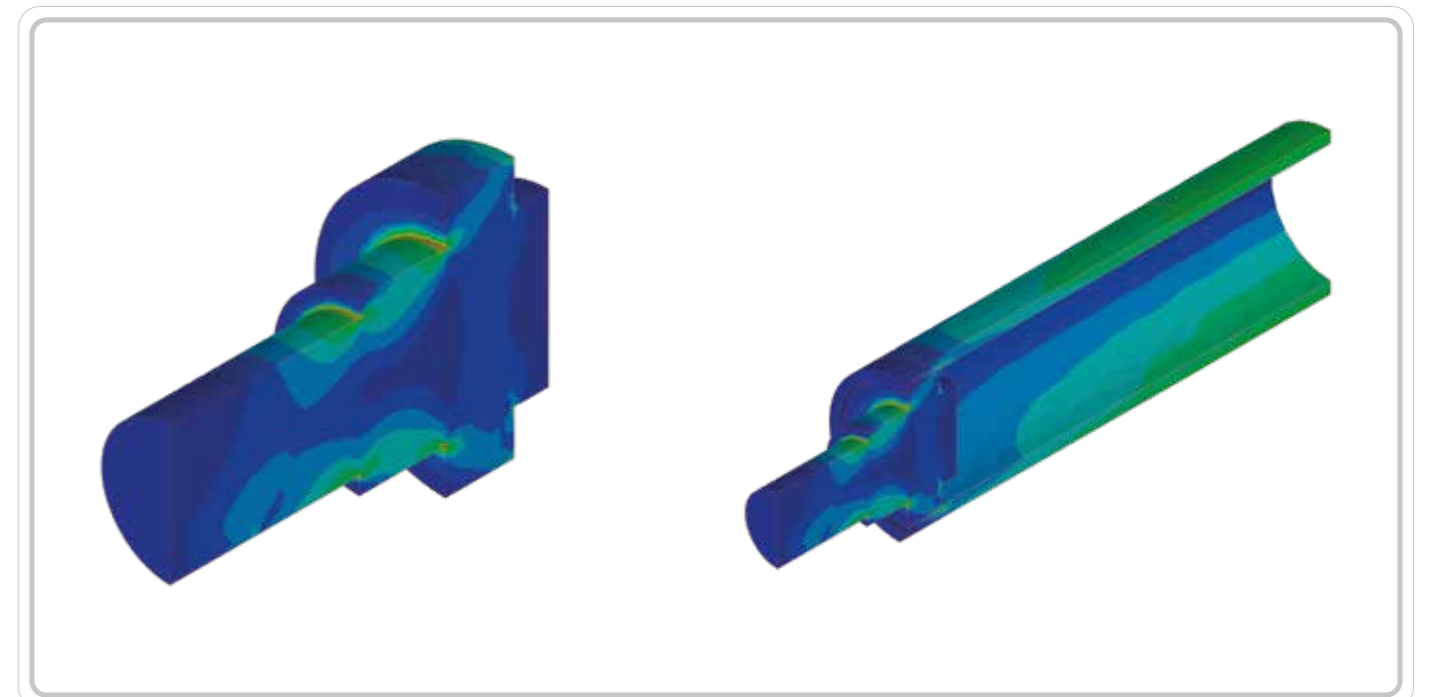
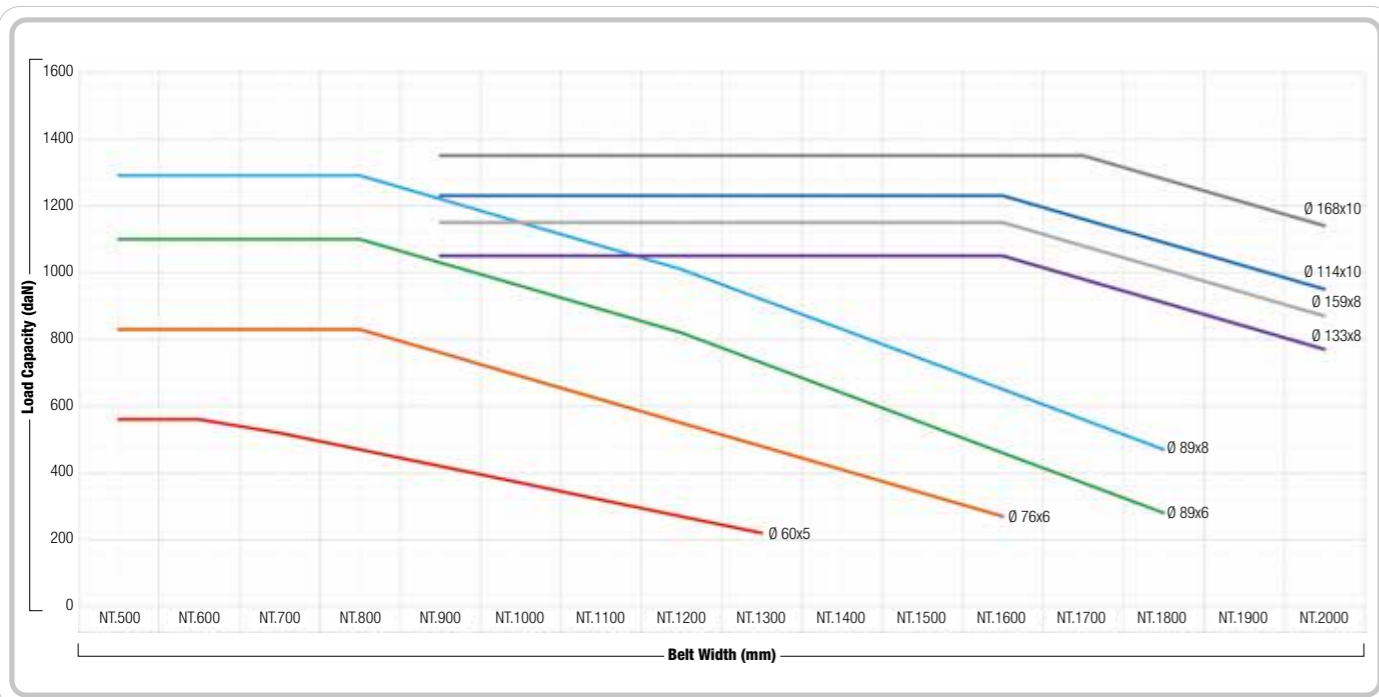

## PS SERIES

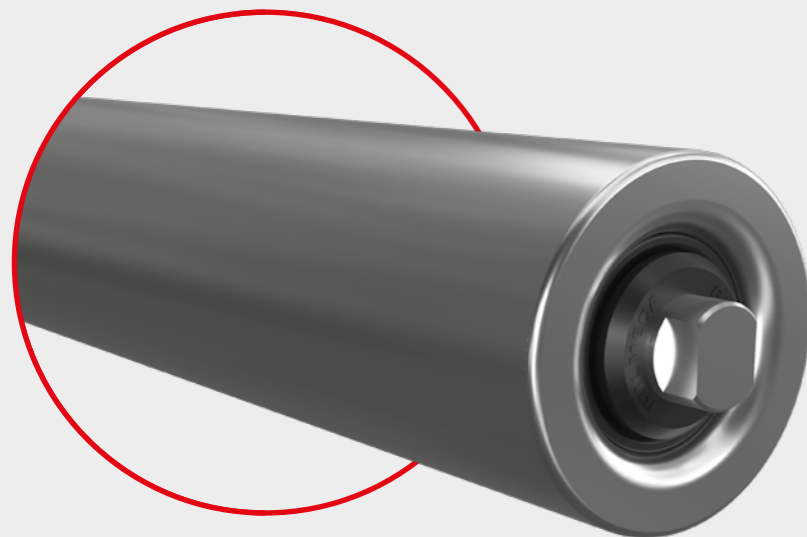

STEEL MONOLITHIC STRUCTURE (UNIBLOC), IDEAL FOR HIGH LOAD GRAVITY CONVEYORS.

MULTIPLE CENTRIFUGAL LABYRINTH SEALING SYSTEM ALLOWS THEIR USE IN INTERNAL, EXTERNAL, DUSTY AND HUMID ENVIRONMENTS.

AVAILABLE IN STAINLESS STEEL VERSION FOR WASH DOWN AND FOOD APPLICATIONS.

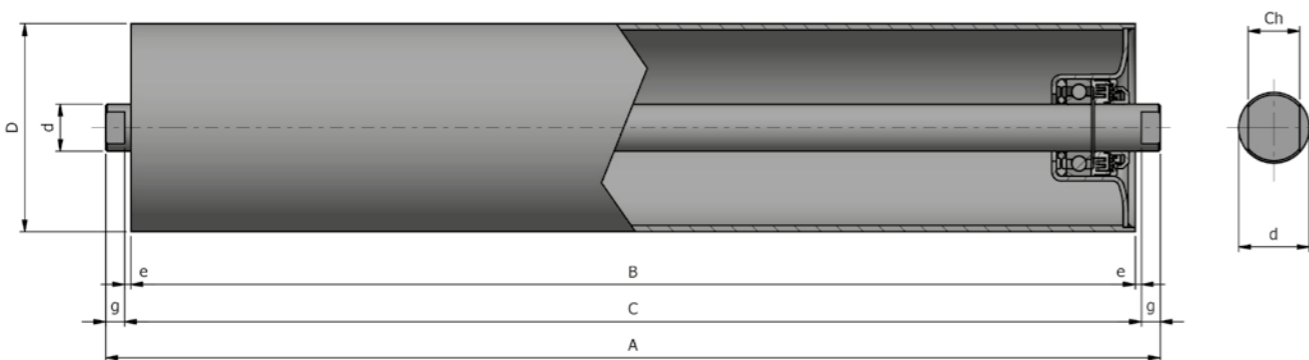

Idle rollers for heavy pallet conveyors in internal, external, normal, dusty and humid environments.

These are quality precision rollers.

The end-caps, gauged to ISO M7, are welded to the tube forming a monolithic structure (UNIBLOC).

The permanently lubricated radial rigid ball bearings are of the 6204-6205-6206-6308 series, of the best brands.

The bearing protection is

guaranteed by a multiple centrifugal labyrinth with cover cap combined with external cap (contact-less), while an internal seal retains a high volume of grease. All parts are made of anticorrosive thermoplastic materials.

The ground steel shaft is internally threaded for screw fixing or has a slot execution.

The application temperatures range from -20° C to + 100° C.

This series features high strength,

perfect balancing and concentricity, minimum starting resistance, precision machining and fit.

Check out PS series sizes on unit handling catalogue available on

[www.rulmeca.com](http://www.rulmeca.com)

## RSP SERIES

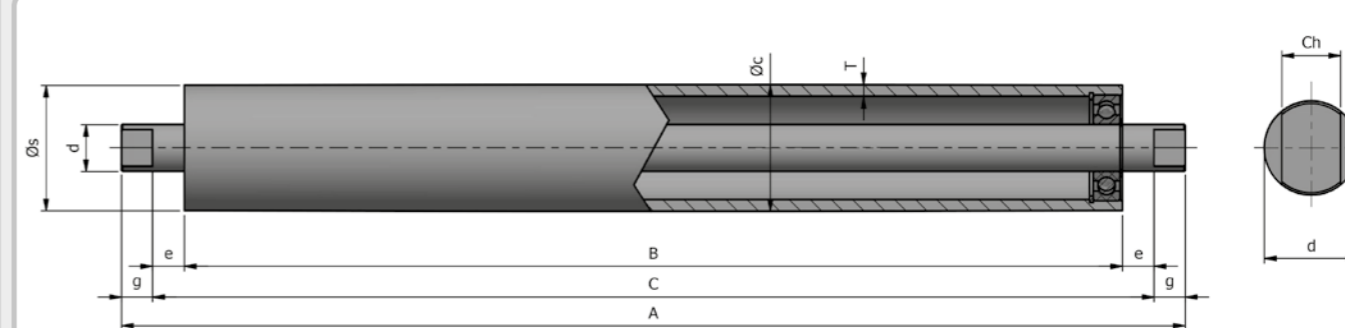
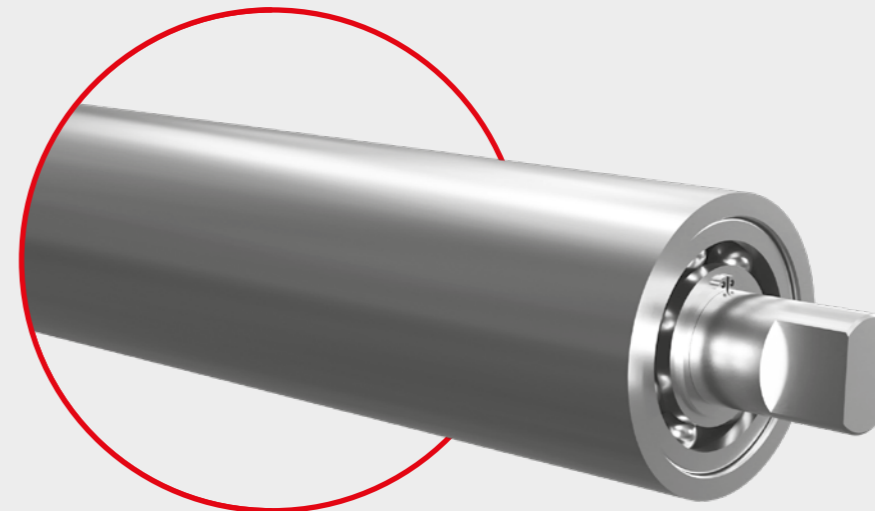

All measures are customizable

Rulmeca has developed a new deflection roller for Unit Handling Belt application. In these rollers we fit the bearings directly into the tube. In this way we obtained a Heavy-

Duty and High Precision roller for heavy applications. The shaft can be threaded and/or slotted

to make installation and belt tensioning much easier.

Rulmeca, thanks to his deep knowledge of belt conveyor applications, can support you in selecting the most suitable dimensions for your needs.

Check out our range of rollers for unit handling applications on

[www.rulmeca.com](http://www.rulmeca.com)

OUR GOAL IS TO ENSURE YOUR APPLICATIONS  
SUCCESS USING OUR PRODUCTS,  
OUR WORLDWIDE TECHNICAL ASSISTANCE IS  
AVAILABLE TO SUPPORT YOU.



BECAUSE  
PARTNERSHIP  
MATTERS



**Group Headquarters: Rulmecca Holding S.p.A.**

Via A. Toscanini, 1 - I-24011 Almè (Bergamo) Italy - Tel +39 035 4300 111 - Fax +39 035 4300390  
export-it@rulmecca.com - www.rulmecca.com





---

VIA MONTE BIANCO 15/17  
20833 GIUSSANO - MB

.....  
INFO@MAPEC.NET  
WWW.MAPEC.NET  
T 0362 311684  
F 0362311007